



C09-M-307/C09-MET-307

3251

BOARD DIPLOMA EXAMINATION, (C-09)

MARCH/APRIL—2018

DME—THIRD SEMESTER EXAMINATION

MACHINE DRAWING

Time : 3 hours]

[Total Marks : 60

PART—A

5×4=20

Instructions : (1) Answer **all** questions.

(2) Each question carries **five** marks.

(3) All dimensions are in mm.

1. Draw two views of gib headed key. 3+2=5

2. Draw two views of double riveted zig-zag lap joint. 3+2=5

3. Draw the single-line symbols for the following pipe fittings : 5

(a) Plug

(b) 90° elbow

(c) Union

(d) Lateral

(e) Glove valve

/3251

1

[Contd...

WWW.MANARESULTS.CO.IN

4. Draw the following weld symbols :

1×5=5

- (a) Single bevel-butt weld
- (b) Single U-butt weld
- (c) Single J-butt weld
- (d) Slot weld
- (e) Flat single V-butt weld

PART—B

40

Instructions : (1) Answer *any one* question.

- (2) Priority should be given to the accuracy, neatness and dimensioning.
- (3) Assume appropriate dimensions if not given in part drawings.

5. Study the given part drawings of cotter joint with gib. Assemble the parts and draw—

- (a) half-sectional front view;
- (b) left side view.

25+15=40

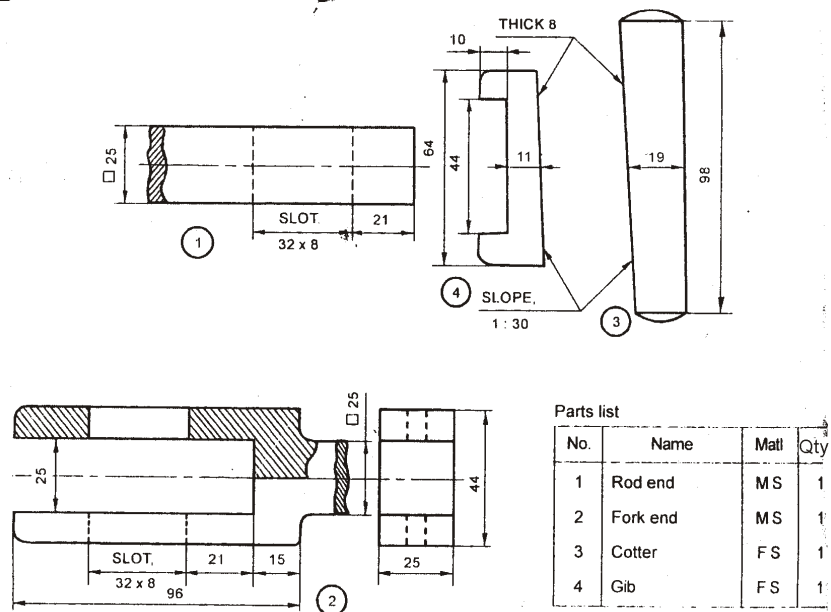

Fig. 1 COTTER JOINT WITH A GIB

6. Study the parts of given protected flanged coupling. Assemble the parts and draw—

- (a) half-sectional front view;
- (b) left side view.

25+15=40

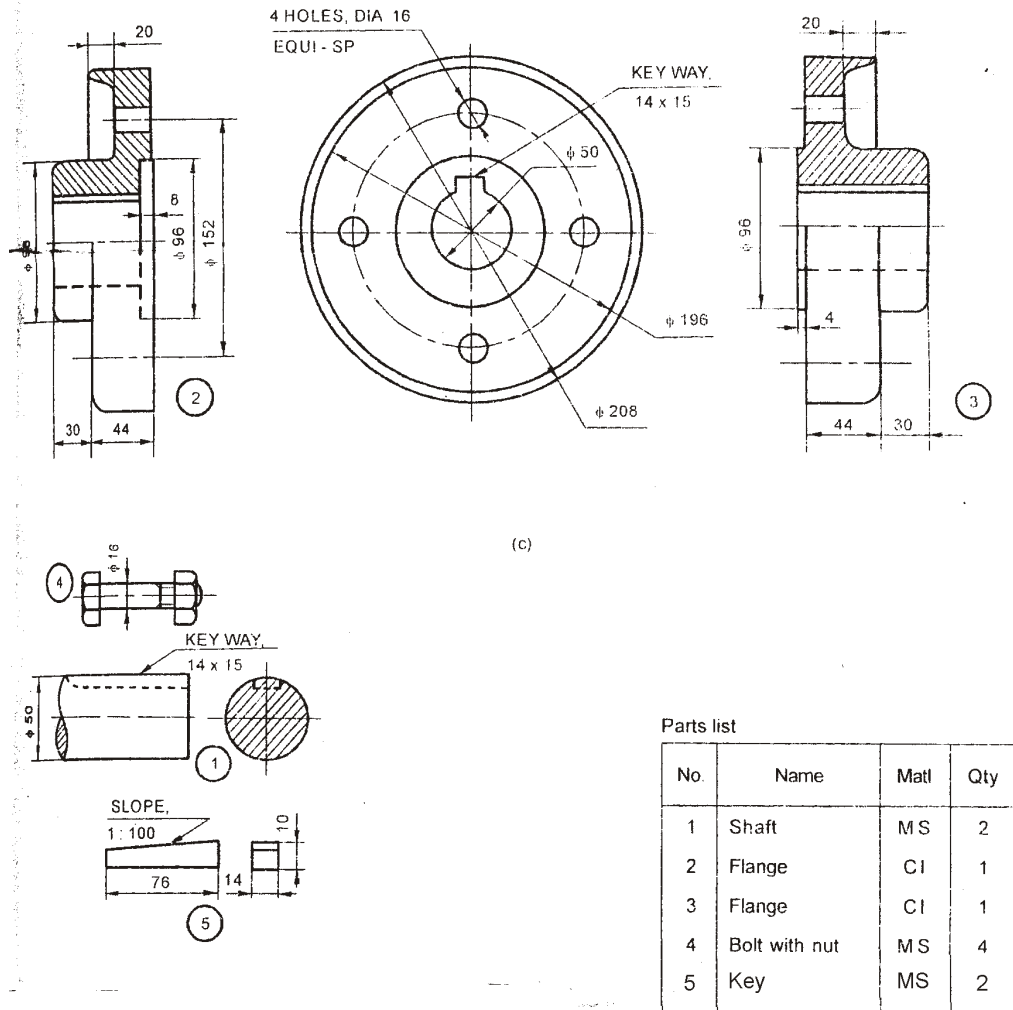

Fig.2 PROTECTED FLANGED COUPLING
