



C14-M-407

4483

BOARD DIPLOMA EXAMINATION, (C-14)

OCT/NOV—2016

DME—FOURTH SEMESTER EXAMINATION

PRODUCTION DRAWING PRACTICE

Time : 3 hours]

[Total Marks : 60

PART—A

5×4=20

Instructions : (1) Answer **all** questions.

(2) Each question carries **five** marks.

(3) Draw neatly with proportionate dimensions.

(4) Use of production drawing tables is allowed.

1. Calculate the value of the hole tolerance, shaft tolerance, minimum allowance, maximum allowance and type of fit for the assembly 40 H7/g6. 1+1+1+1+1=5
2. Write the surface roughness values for the following manufacturing processes : 5
 - (a) Lapping
 - (b) Reaming
 - (c) Drilling
 - (d) Forging
 - (e) Die casting
3. Explain the following designations : 2+1+2=5
 - (a) Hex bolt M20 × 1.5 × 75 IS : 1364-S-4.6
 - (b) Fe 410 CuK
 - (c) Taper Key 12 × 8 × 50, IS : 2292
4. List various reprographic methods for reproducing engineering drawings. 5

/4483

1

[Contd...

WWW.MANARESULTS.CO.IN

- Instructions :** (1) Answer *any one* question.
 (2) Each question carries **forty** marks.

5. Study the given assembly drawing of the crank shown in Fig. 1 :

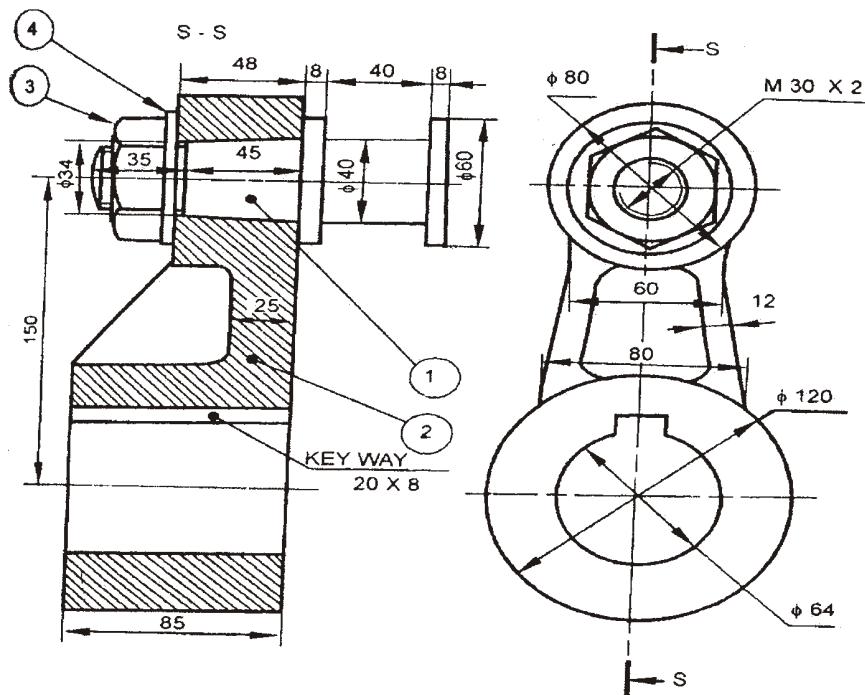

Fig. 1

Parts List

<i>Part List</i>	<i>Name</i>	<i>Qty.</i>
1	Crank pin	1
2	Crank	1
3	Nut	1
4	Washer	1

- (a) Draw the component drawings.
 (b) Apply suitable tolerances and fits.
 (c) Apply suitable geometrical tolerances to components.
 (d) Prepare the process sheet for crank pin.
 (e) Show the surface roughness symbols.
 (f) List out the materials of the components. 20+5+4+5+4+2=40

6. Study the given assembly drawing of the foot-step bearing shown in Fig. 2 :

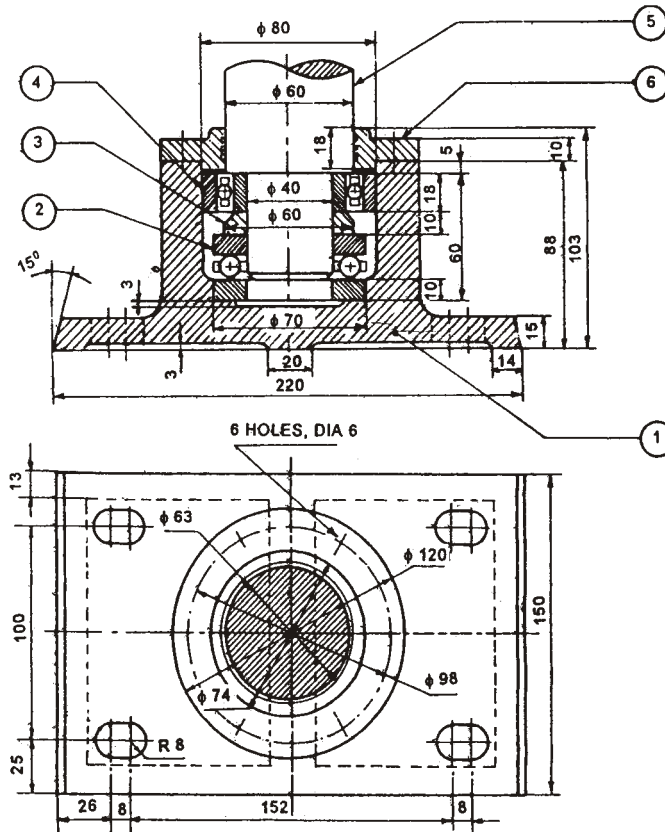

Fig. 2

Parts list

Part No.	Name	Qty.
1	Base	1
2	Thrust ball bearing	1
3	Spacer	1
4	(Radial) ball bearing	1
5	Shaft	1
6	Cover	1

- (a) Draw the component drawings.
 (b) Apply suitable tolerances and fits.
 (c) Apply suitable geometrical tolerances to components.
 (d) Prepare the process sheet for cover.
 (e) Show the surface roughness symbols.
 (f) List out the materials of the components. 20+5+4+5+4+2=40

★ ★ ★