



C14-M-502

4650

BOARD DIPLOMA EXAMINATION, (C-14)
MARCH/APRIL—2018
DME—FIFTH SEMESTER EXAMINATION
DESIGN OF MACHINE ELEMENTS—II

Time : 3 hours]

[Total Marks : 80

PART—A

3×10=30

- Instructions** : (1) Answer **all** questions.
(2) Each question carries **three** marks.
(3) Answers should be brief and straight to the point and shall not exceed *five* simple sentences.
1. Mention any three important factors required to select a suitable power transmission drive.
 2. Write any three advantages of chain drive over belt drive.
 3. Define the following terms relating to gear :
 - (a) Circular pitch
 - (b) Diametral pitch
 - (c) Module
 4. State 'law of gearing'.
 5. What is the function of flywheel?
 6. Define the following terms relating to governor :
 - (a) Sensitiveness
 - (b) Stability
 7. What is clutch? State its function.

8. What are the materials used for brake lining?
9. Define the following terms related to cam :
- (a) Dwell
- (b) Base circle
- (c) Stroke or lift
10. Sketch different types of follower.

PART—B

10×5=50

Instructions : (1) Answer *any five* questions.

(2) Each question carries **ten** marks.

(3) Answers should be comprehensive and the criterion for valuation is the content but not the length of the answer.

11. A lather belt, 110 mm wide and 5 mm thick transmits power from a pulley of 740 mm diameter running at 500 r.p.m. making an angle of lap 165° , coefficient of friction (μ) 0.28, mass of the belt is 0.75 kg/m length, the permissible stress is 2.75 MN/m^2 . Compute the maximum power that can be transmitted.

12. (a) A shaft running at 120 r.p.m. carries a pulley of 400 mm diameter which drives a dynamo at 1000 r.p.m. by means of a belt 10 mm thickness. Allow the thickness of belt and a total slip of 5%, determine the diameter of the pulley on the dynamo.

5

(b) Explain velocity ratio of simple gear train.

5

13. Draw and explain the back gear arrangement of lathe.

14. A flywheel rotating at 600 r.p.m. does 1950 J of work/rev. The coefficient of fluctuation of energy is 0.22 and that of the speed is 1.1 mass of the flywheel is 90 kg. Compute (a) power transmitted by the shaft on which flywheel is mounted, (b) maximum fluctuation of energy, (c) mass moment of inertia and (d) diameter of the flywheel.

15. (a) Explain the function of governor with a neat sketch. 5
- (b) A single shoe brake is shown in figure below. The coefficient of friction between the brake lining and the drum is 0.3. If the drum rotates clockwise, find the braking torque due to operation force of 600 N : 5

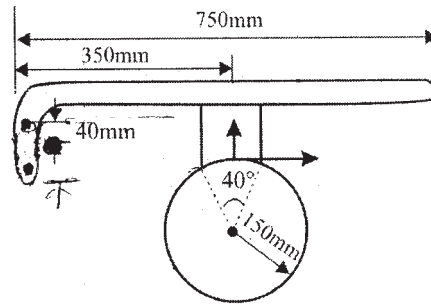

16. In a single disc clutch, the outside diameter of contact surface is 280 mm and inside diameter is 180 mm. If $\mu = 0.2$ and the allowable normal pressure is 0.12 N/mm^2 , calculate—
- (a) axial force;
- (b) power transmitted at 900 r.p.m. for uniform pressure.
17. (a) Explain positive clutches with the help of neat sketch.
- (b) Explain the construction of displacement diagram for a follower moving with uniform velocity. 5+5
18. Draw the profile of cam operating a knife edge follower from the following data :
- (a) Lifts follower through 40 mm during 60 degrees with SHM
- (b) The follower remains at rest for the next 45 degrees of rotation of the cam.
- (c) The follower then descends to its original position during 90 degrees rotation of cam with SHM.
- (d) The follower remains at rest for the remaining part of the revolution
- The least diameter of the cam is 50 mm, the axis of knife edge follower passes through the axis of the cam shaft.
