



*

C16-M-502

6638

BOARD DIPLOMA EXAMINATION, (C-16)

AUGUST/SEPTEMBER—2021

DME - FIFTH SEMESTER EXAMINATION

INDUSTRIAL ENGINEERING, ESTIMATING AND COSTING

Time : 3 hours]

[Total Marks : 80

PART—A

3×10=30

Instructions : (1) Answer all questions.

(2) Each question carries three marks.

(3) Answers should be brief and straight to the point and shall not exceed five simple sentences.

1. What is the role of work measurement to increase productivity?
2. Define method study. Write any two aims of method study.
3. Write any three methods of time study.
4. What are the advantages of statistical quality control?
5. Write any three differences between variable charts and attribute charts.
6. What are the main elements of cost?
7. Write any three examples of selling and distribution overheads.
8. Write the formula for finding the volume of (a) cylinder, (b) cone and (c) sphere.
9. Find the RPM for turning a steel shaft of 125 mm diameter at a cutting speed of 20 m/min.
10. State the various costs involved in estimating foundry costs.

/6638

1

[Contd...

*

* PART—B

Instructions : (1) Answer *any* five questions.

(2) Each question carries ten marks.

(3) Answers should be comprehensive and criterion for valuation is the content but not the length of the answer.

- | | | |
|-----|--|----|
| 11. | Describe the procedure for method study. | 10 |
| 12. | Define standard time. Explain the constituents of standard time | 10 |
| 13. | (a) Determine the sample size of an automatic screw cutting machine by work sampling for a confidence level of 95% and an accuracy of 5%. Assume proportion of idle machine time as 25%. | 5 |
| | (b) Write the advantages of PMTS. | 5 |
| 14. | Draw a neat sketch of on OC curve. Explain its different regions and also salient points on the curve. | 10 |
| 15. | Estimate the volume of material required for producing 1000 parts as shown in the figure below. Assume that 15% of the finished material is wasted during finishing. | 10 |

Density of material is 7.8 grams/cc

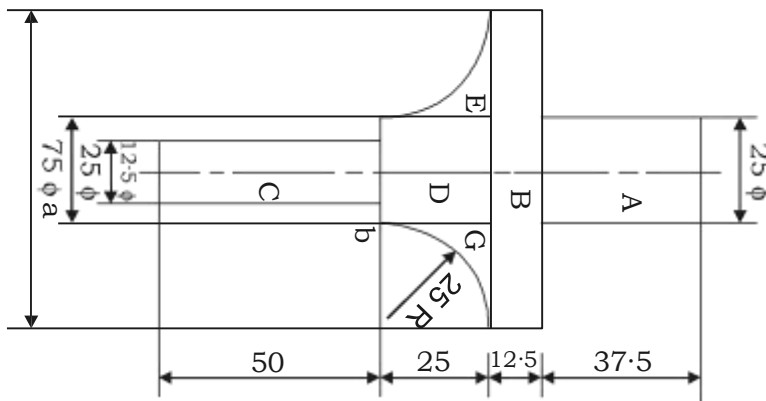

All dimensions are in mm

Figure

16. Find the time*required to turn a 60 mm diameter rod to the dimensions shown in below figure. Take cutting speed as 20 m/min and feed as 1.2 mm.

All cuts are 3 mm deep.

10

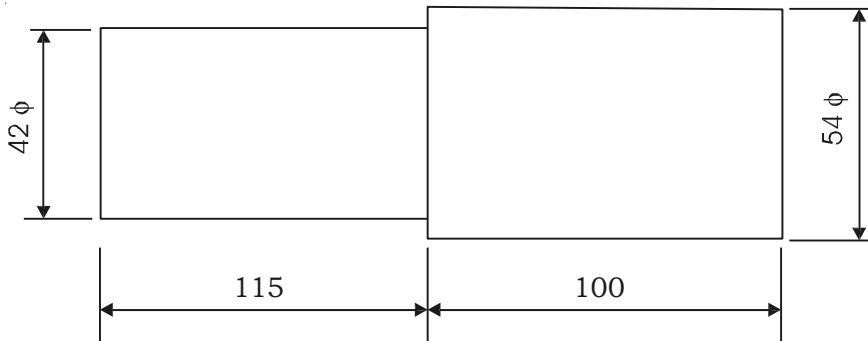

All dimensions are in mm

Figure

17. (a) Write the formula for finding volume of (i) Circular ring and (ii) Frustum of Pyramid. 2½+2½=5
- (b) Briefly explain the various losses in forging operation. 5
18. A container of size 2 m × 1 m × 0.5 m height is to be fabricated from 6mm thick plates. The plate metal density is 8 grams/CC. The top of the container is open and the joints are to be welded. 10

Calculate the cost of container. Assume the following data.

- (a) Cost of plate = ₹ 10/kg.
- (b) Metal Scrap = 5% of metal
- (c) Cost of labour = 10% material cost
- (d) Cost of welding material = ₹ 5/ meter weld

★ ★ ★