

**ENGINEERING DRAWING**

(Common to ECE, EEE, EIE, Bio-Tech, EComE, Agri.E)

Time: 3 hours

Max. Marks: 70

Question Paper Consists of **Part-A** and **Part-B**  
 Answering the question in **Part-A** is Compulsory,  
 Three Questions should be answered from **Part-B**

\*\*\*\*\*

**PART-A**

- 1.(a) Draw the projections of a triangular prism, base 40 mm side and axis 50 mm long, resting on one of its bases on the H.P. with a vertical face perpendicular to the V.P.
- (b) Draw the isometric view of the given two views.

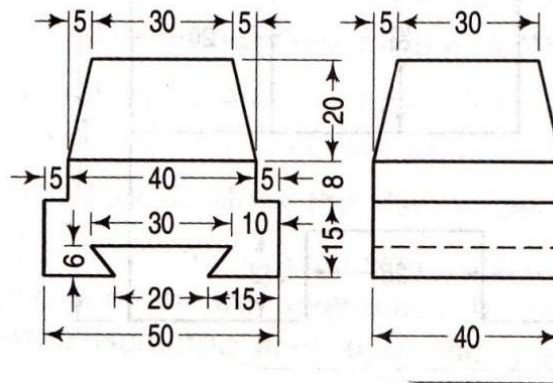

[10+12]

**PART-B**

- 2.(a) A point P is 20 mm below H.P. and lies in the third quadrant. Its shortest distance from xy is 40 mm. Draw its projections.
  - (b) The major and minor axes of an ellipse are 140 mm and 90 mm respectively. Find the foci and draw the ellipse using arcs of circle method. Draw a tangent and a normal to the ellipse at a point 40 mm above the major axis.
- [8+8]
- 3.(a) The distance between two stations by road is 200 km and it is represented on a certain map by a 5 cm long line. Find the R.F. and construct a diagonal scale showing single kilometre and long enough to measure up to 600 km. Show a distance of 467 km on this scale.
  - (b) The front view of a 75 mm long line measures 55 mm. The line is parallel to the H.P. and one of its ends is in the V.P. and 25 mm above the H.P. Draw the projections of the line and determine its inclination with the V.P.
- [8+8]
4. A line AB, inclined at  $40^\circ$  to the V.P., has its ends 50 mm and 20 mm above the H.P. The length of its front view is 65 mm and its V.T. is 10 mm above the H.P. Determine the true length of AB, its inclination with the H.P. and its H.T.

[16]



- 5. A hexagonal plane of side 30 mm has a corner on the ground. Its surface is inclined at  $45^\circ$  to the H.P. and the top view of the diagonal through the corner which is in the H.P. makes an angle of  $60^\circ$  with the V.P. Draw its projections. [16]
- 6. A cone of base diameter 50 mm and axis 60 mm has a generator in the V.P. and the axis parallel to the H.P. Draw its projections. [16]
- 7. Draw the front, top and side views for the following figure. All dimensions are in mm. [16]

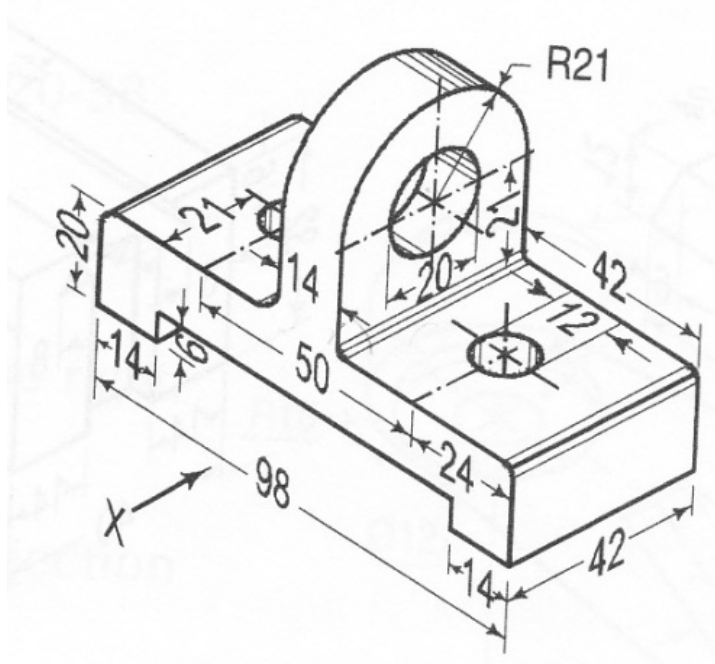

[16]

\*\*\*\*\*



**Subject Code: R13109/R13**

**Set No - 2**

**I B. Tech I Semester Supplementary Examinations July - 2015**

**ENGINEERING DRAWING**

(Common to ECE, EEE, EIE, Bio-Tech, EComE, Agri.E)

**Time: 3 hours**

**Max. Marks: 70**

Question Paper Consists of **Part-A** and **Part-B**  
Answering the question in **Part-A** is Compulsory,  
Three Questions should be answered from **Part-B**

\*\*\*\*\*

**PART-A**

- 1.(a) The major axis of an ellipse is 150 mm long and the minor axis is 100 mm long. Find the foci and draw the ellipse by 'arcs of circles' method. Draw a tangent to the ellipse at a point on it 25 mm above the major axis.
- (b) A cylinder block of base, 60 mm diameter and height 80 mm, standing on the H.P. with its axis perpendicular to the H.P. Draw its isometric view.

[10+12]

**PART-B**

- 2.(a) Two points A and B are in the H.P. The point A is 30 mm in front of the V.P., while B is behind the V.P. The distance between their projectors is 75 mm and the line joining their top views makes an angle of  $45^\circ$  with xy. Find the distance of the point B from the V.P.
  - (b) The distance between two stations is 100 km and on a road map it is shown by 30 cm. Draw a diagonal scale and mark 46.8 km and 32.4 km on it.
- [8+8]
- 3.(a) An 80 mm long line MN has its end M, 15 mm in front of the V.P. The distance between the ends projector is 50 mm. The front view is parallel to and 20 mm above reference line. Draw the projections of the line and determine its inclination with the V.P.
  - (b) A line PQ 100 mm long, is inclined at  $30^\circ$  to the H.P. and at  $45^\circ$  to the V.P. Its mid-point is in the V.P. and 20 mm above the H.P. Draw its projections, if its end P is in the third quadrant and Q in the first quadrant.
- [8+8]
4. A line PQ inclined at  $30^\circ$  to the V.P. has the end P, 15 mm above the H.P. Its front view measures 70 mm and is inclined at  $45^\circ$  to reference line. The V.T. of the line is 25 mm below the H.P. Draw the projections of the line PQ and determine its true length and the H.T.
- [16]
5. The diagonals of a rhombus measure 100 mm and 40 mm. The longer diagonal is inclined at  $30^\circ$  to H.P. with an end in H.P. and the smaller diagonal is parallel to both the principal planes. Draw its projections.
- [16]
6. A hexagonal pyramid of base edge 30 mm and axis 60 mm, is lying on a slant edge on the ground with the axis parallel to the V.P. Draw its projections when the face containing the resting edge are equally inclined to the H.P.

[16]



7. Draw the front, top and side views for the following figure. All dimensions are in mm.

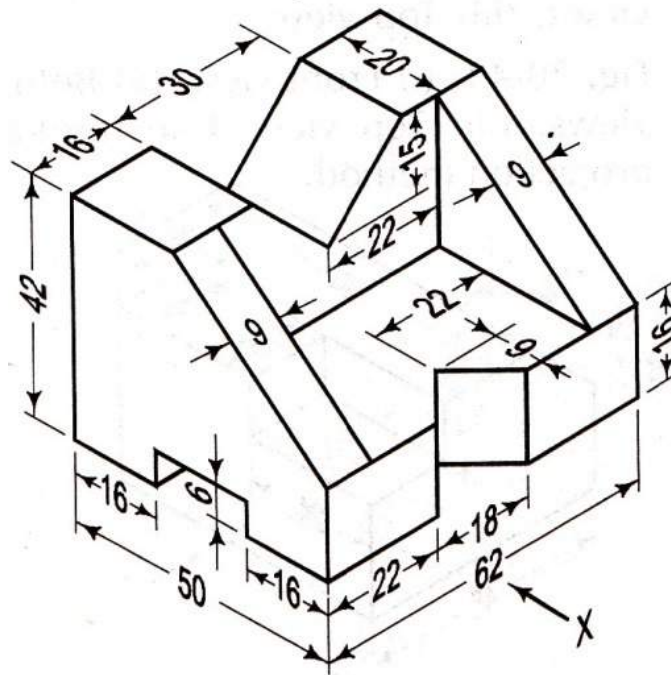

[16]

\*\*\*\*\*



I B. Tech I Semester Supplementary Examinations July - 2015

**ENGINEERING DRAWING**

(Common to ECE, EEE, EIE, Bio-Tech, EComE, Agri.E)

Time: 3 hours

Max. Marks: 70

Question Paper Consists of **Part-A** and **Part-B**  
 Answering the question in **Part-A** is Compulsory,  
 Three Questions should be answered from **Part-B**

\*\*\*\*\*

**PART-A**

- 1.(a) A line AB, 90 mm long, is inclined at  $45^\circ$  to the H.P. and its top view makes an angle of  $60^\circ$  with the V.P. The ends A is in the H.P. and 12 mm in front of the V.P. Draw its front view and find its true inclination with the V.P.
- (b) Draw the front, top and side views for the following figure. All dimensions are in mm.

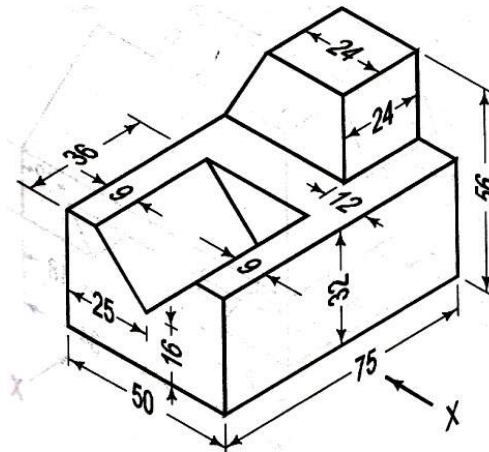

[10+12]

**PART-B**

- 2.(a) A point 30 mm above xy line is the plan-view of two points P and Q. The elevation of P is 45 mm above the H.P. while that of the point Q is 35 mm below the H.P. Draw the projections of the points and state their position with reference to the principal planes and the quadrant in which they lie.
  - (b) The foci of an ellipse are 90 mm apart and the minor axis is 65 mm long. Determine the length of the major axis and draw the ellipse by oblong method.
- [8+8]
- 3.(a) If 1 cm long line on a map represents a real length of 4 m. Calculate the R.F. and draw a vernier scale long enough to measure up to 50 m. Show a distance of 44.5 m in it.
  - (b) A 55 mm long line PQ is perpendicular to the H.P. and 25 mm in front of the V.P. Draw its projections when one end of the line is 15 mm above the H.P.

[8+8]



4. The front view of a line PQ is inclined at  $30^\circ$  to the reference line. The H.T. of the line is 30 mm in front of the V.P. whereas the V.T. is 20 mm below the H.P. One end of the line is 15 mm above the H.P. and the other end of the line is 100 mm in front of the V.P. Draw the projections of the line PQ and determine its true length and true angles of inclination with the reference planes. [16]
5. A 30 – 60 set-square has its 75 mm long hypotenuse in the V.P. and inclined at  $30^\circ$  to the H.P. The surface is inclined at  $45^\circ$  to the V.P. Draw three views of the set-square. [16]
6. A pentagonal pyramid of base side 30 mm and axis 55 mm has a triangular face in the V.P. and the base edge contained by that triangular face is perpendicular to the H.P. Draw its projections. [16]
7. Draw the isometric view of the given two views. [16]

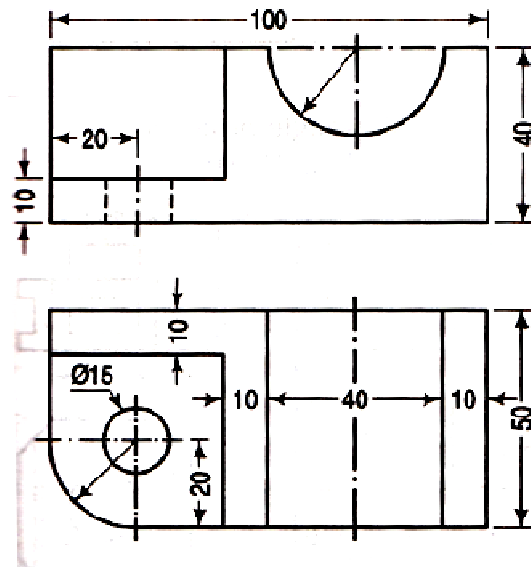

[16]

\*\*\*\*\*



Subject Code: R13109/R13

Set No - 4

I B. Tech I Semester Supplementary Examinations July - 2015

**ENGINEERING DRAWING**

(Common to ECE, EEE, EIE, Bio-Tech, EComE, Agri.E)

Time: 3 hours

Max. Marks: 70

Question Paper Consists of **Part-A** and **Part-B**  
Answering the question in **Part-A** is Compulsory,  
Three Questions should be answered from **Part-B**

\*\*\*\*\*

**PART-A**

- 1.(a) An 80 mm long line PQ has its end P, 10 mm above the H.P. and 25 mm in front of the V.P. The line is inclined at  $30^\circ$  to the H.P. and  $60^\circ$  to the V.P. Draw its projections.
- (b) A plate having shape of an isosceles triangle has base 40 mm and altitude 54 mm. It is so placed that in the front view it is seen as an equilateral triangle of side 40 mm having a side inclined at  $45^\circ$  to the reference line. Draw its top view.

[12+10]

**PART-B**

- 2.(a) A point P is in the first quadrant. Its shortest distance from the intersection point of H.P., V.P. and Auxiliary vertical plane, perpendicular to the H.P. and V.P. is 70 mm and it is equidistant from principle planes( H.P. and V.P.). Draw the projections to the point and determine its distance from the H.P. and V.P.
  - (b) Draw a vernier scale of R.F. =  $\frac{1}{25}$  to read centimetres up to 4 metres and on it, show lengths representing 2.39 m and 0.91 m.
- [8+8]
- 3.(a) The front view of a line, inclined at  $30^\circ$  to the V.P. is 65 mm long. Draw the projections on the line, when it is parallel to and 40 mm above the H.P., its one end being 30 mm in front of the V.P.
  - (b) Inscribe an ellipse in a parallelogram having sides 150 mm and 100 mm long and an included angle of  $120^\circ$ .
- [8+8]
4. A 100 mm long line PQ has the end P 50 mm in front of the V.P. The H.T. is 60 mm in front of the V.P. and V.T. is 80 mm above the H.P. The distance between the H.T. and the V.T. is 130 mm. Draw the projections of the line PQ and determine its inclinations with the H.P. and the V.P.
- [16]
5. A pentagonal prism of base side 30 mm and axis 60 mm has one of its rectangular faces on the H.P. and the axis inclined at  $60^\circ$  to the V.P. Draw its projections.
- [16]
6. Draw the isometric view of a hexagonal pyramid of base side 30 mm and axis 60 mm long. The pyramid is kept on its base on the V.P.
- [16]



7. Draw the front, top and side views for the following figure. All dimensions are in mm.

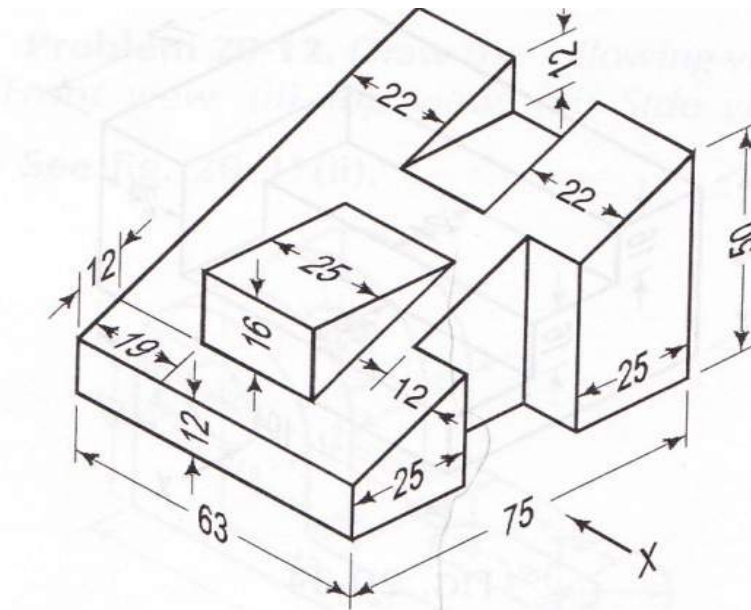

[16]

\*\*\*\*\*

