

**I B. Tech I Semester Supplementary Examinations Dec - 2016**  
**ENGINEERING MECHANICS**

(Common to CE, ME, CSE, PCE, IT, ChemE, AeroE, AME, MinE, PE, MetalE, Textile Engg.)

**Time: 3 hours**

**Max. Marks: 70**

Question Paper Consists of **Part-A** and **Part-B**  
 Answering the question in **Part-A** is Compulsory,  
**Three** Questions should be answered from **Part-B**

\*\*\*\*\*

**PART-A**

1. a) What is mechanics? What is its importance?
- b) State and prove Lami's theorem.
- c) State pappus theorems.
- d) Give the expression for mass moment of inertia of a solid sphere.
- e) Define time of flight.
- f) Explain the applications of work-energy equation. (3M+4M+4M+4M+3M+4M)

**PART-B**

2. Find the magnitude and direction of the resultant of the concurrent forces of 80 N, 120 N, 150 N and 200 N making angles of 30°, 70°, 120° 15' and 155° respectively with the X – axis.
3. A tripod supports a load of 2kN as shown in Figure below. The ends P, Q and R are in the x-z plane. Find the force in the three legs of the tripod.

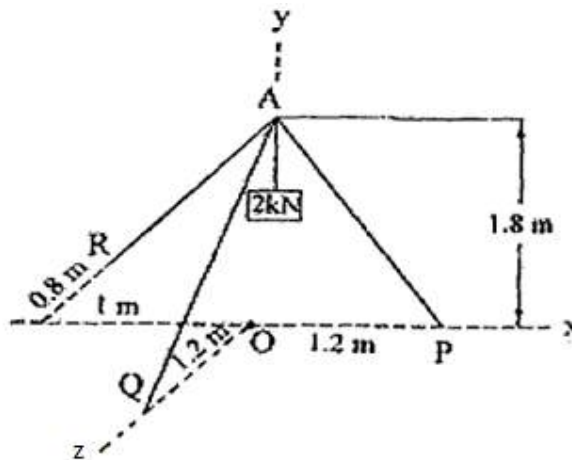

4. Locate the centroid of the shaded area shown in Figure below.

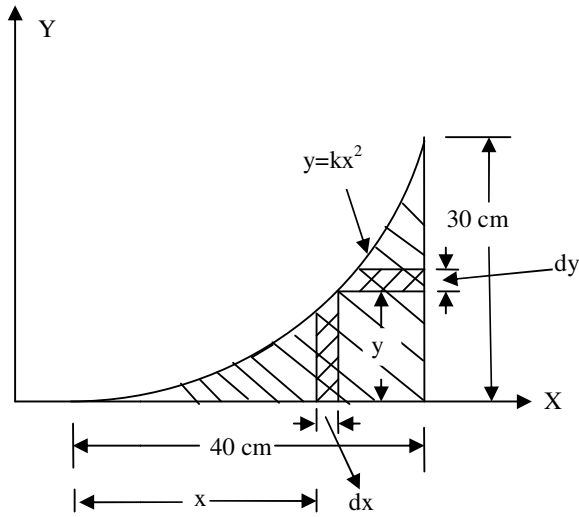

5. Calculate the moment of inertia of the section shown below about the XX and YY axis through the centroid.

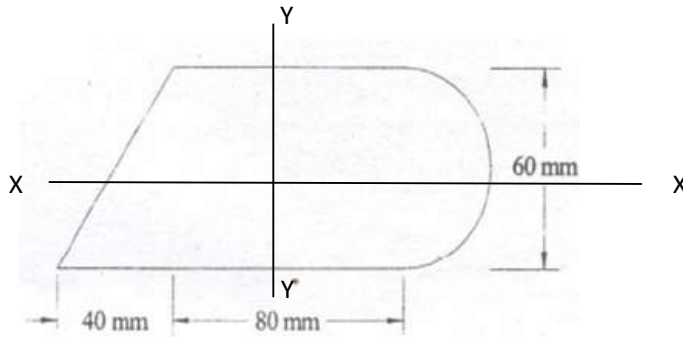

6. The rectilinear motion of a particle is given by the relation  $x = t^3 - 60t$ , where  $x$  is in metres and  $t$  is in seconds. Calculate
- velocity when  $t = 6$  s
  - average velocity over the 8<sup>th</sup> second
  - position when it stops momentarily
  - the acceleration and velocity at the instant when it passes through the origin again.
7. A chord passes over a mass less and friction less pulley as shown below carrying a block A of mass 175 kg at one end and wrapped around a cylinder of mass 250 kg which rolls on a horizontal plane. Determine i) Acceleration of block A ii) Tension in the cord

