

**I B. Tech I Semester Regular/Supplementary Examinations, Oct/Nov - 2018****ENGINEERING DRAWING**

(Common to ECE, EIE, ECom E)

Time: 3 hours

Max. Marks: 70

- Note: 1. Question Paper consists of two parts (**Part-A** and **Part-B**)  
 2. Answering the question in **Part-A** is Compulsory  
 3. Answer any **FOUR** Questions from **Part-B**

**PART -A**

1. a) Write the following caption as per BIS lettering “ENGINEERING DRAWING IS A LANGUAGE OF ENGINEERS” (2M)
- b) Perform a geometrical construction operation to divide a straight of length 120mm into 7 equal parts. (2M)
- c) Draw the projections of a point ‘S’ in the I-quadrant and a convenient distance from both the planes of projection. (2M)
- d) What is the top view of a hexagonal plane of length of its side 30mm when it is parallel to the HP and one side makes an angle  $45^0$  with the VP? (4M)
- e) Draw the front view of a cone 30mm base 50mm height standing of the HP. (4M)

**PART -B**

2. a) The major and minor axes of an ellipse are 120mm and 80mm. Draw an ellipse by foci or arc of circles method. (7M)
- b) Draw a diagonal scale of R.F. =1/75 to show metres, decimeters and centimeters and to measure up to 6 metres. Mark a length of 3.75 metres on it. (7M)
3. a) Draw the projections of the following points in third quadrant when the (7M)
  - (i) Point A lies in the HP and 22mm away from the VP.
  - (ii) Point B lies in the VP and 32mm away from the HP.
  - (iii) Point C lies 32mm from the HP and 22mm from the VP.
- b) A line PQ 60mm long has its end P 30 mm above HP and 45mm in front of VP. Its top view (plan) has a length of 50mm. Draw its projections and find the inclination of the line with HP. (7M)



4. a) A line AB is 75 mm long. A is 50 mm in front of VP and 15 mm above HP. B is 15 mm in front of VP and is above HP. Top View of AB is 50mm long. Draw and measure the front view. Find the true inclinations. (7M)
- b) A line AB of 70 mm long has its end A at 10 mm above HP and 15 mm in front of VP. Its front view and top view measures 50 mm and 60 mm respectively. Draw the projections of the line and determine its inclinations with HP and VP. (7M)
5. a) Draw the projections of a circle of 5 cm diameter, having its plane vertical and inclined at  $30^\circ$  to VP Its center is 3 cm above the HP and 4 cm in front of the VP. (7M)
- b) A pentagonal plate of 35 mm side is perpendicular to the VP and parallel to HP. One of its edges is perpendicular to the VP Draw its projections. (7M)
6. a) Draw the projection of a rectangular pyramid of height 60 mm and base edge 30mm resting on a corner with the slanting edge containing the above corner at  $60^\circ$  with the HP. (7M)
- b) A pentagonal pyramid, side of pentagon 30 mm and height 70 mm is resting on the HP on one of its base edges such that the triangular face containing that edge is perpendicular to the HP and parallel to VP. Draw the projections. (7M)
7. Draw the isometric view of the following orthographic projections. (14M)

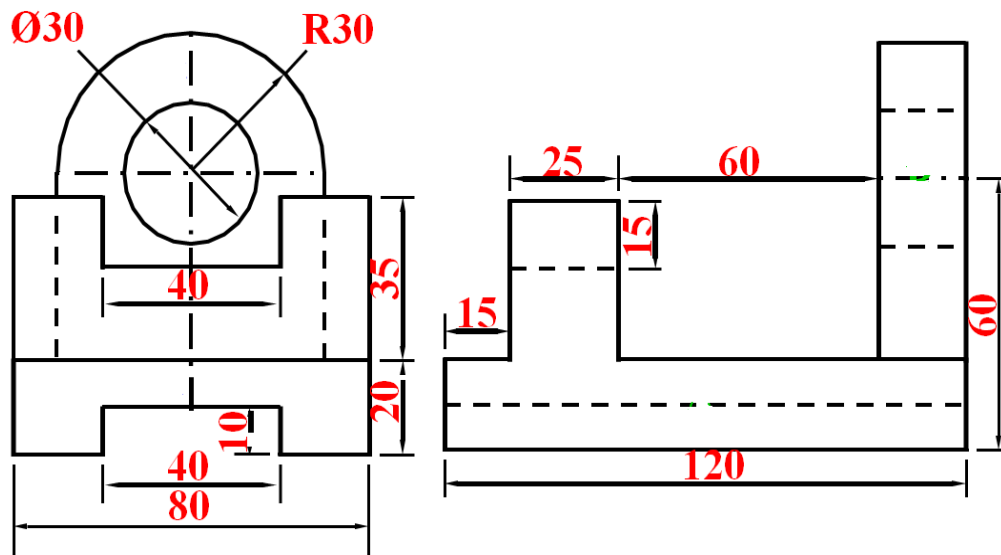

Code No: R161113

**R16**

**SET - 2**

**I B. Tech I Semester Regular/Supplementary Examinations, Oct/Nov - 2018**

**ENGINEERING DRAWING**

(Common to ECE, EIE, ECom E)

Time: 3 hours

Max. Marks: 70

- Note: 1. Question Paper consists of two parts (**Part-A** and **Part-B**)  
2. Answering the question in **Part-A** is Compulsory  
3. Answer any **FOUR** Questions from **Part-B**

**PART -A**

1. a) Draw the projections of a point 'D' on the VP and 30mm in above the HP. (2M)
- b) Draw the projections of a straight line CD of length 80mm when it contained by profile plane with its end C on the HP while the other 20mm in front of the VP. (4M)
- c) What is the front view of a pentagonal plane of length of its side 30mm when it is parallel to the VP and one side makes an angle  $30^0$  with the HP? (4M)
- d) Draw the top view of a cylinder 30mm base 50mm height standing of the VP. (4M)

**PART -B**

2. a) Draw a Vernier scale of RF=1/25 to read up to 4m. On it show lengths 2.39m and 0.91m. (7M)
- b) The major and minor axes of an ellipse are 120 mm and 70 mm respectively. Find the foci and draw the ellipse using arcs of circles method. Draw a tangent and normal to the ellipse at a point 40 mm above the major axes. (7M)
3. a) Draw the projections of straight line AB 65mm long parallel to H.P and inclined at an angle of  $45^0$  to V.P. The end A is 26mm above H.P and 18mm in front of V.P. (7M)
- b) (i) A point A is 2.5 cm above the HP and 3 cm in front of the VP. Draw its Projections. (7M)  
(ii) A point A is 2 cm below the HP and 4 cm behind the VP. Draw its Projections.
4. A straight line PQ has its end P at 20 mm above the HP and 30 mm in front of the VP and end Q is 80 mm above the HP and 70 mm in front of VP. If the end projectors are 60 mm apart. Draw the projections of the line. Determine its true length and true inclinations with the reference planes. (14M)
5. a) The rhombus having diagonals 120mm and 70mm is so placed that its smaller diagonal is parallel to both the planes and the larger diagonal is inclined at  $45^0$  to the HP. Draw its projections. (7M)
- b) A hexagonal lamina with a 30mm long side has one of the sides perpendiculars to the VP. The surface of the lamina is parallel to and 15mm above the HP. Draw its Projections? (7M)



6. a) A square pyramid of base edge 30 mm and altitude 40mm has one of its slant faces in the VP, and the edge of the base contained by that face is inclined at  $45^\circ$  to the HP. Draw the projections of the pyramid when the vertex is in the HP. (7M)
- b) A hexagonal pyramid of 30 mm side of base and 45 mm length of axis is resting on one of its triangular faces on HP. Draw the projections of the pyramid when its edge inclined at  $60^\circ$  to the VP. (7M)
7. Draw the three orthographic views of a following pictorial projection. (14M)

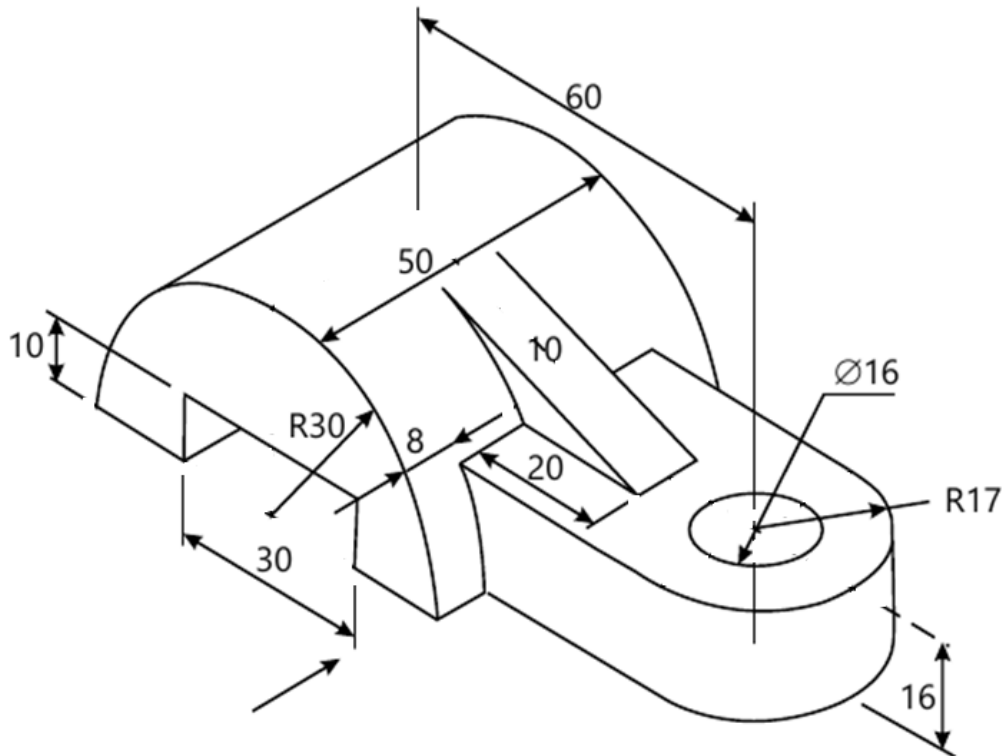

**I B. Tech I Semester Regular/Supplementary Examinations, Oct/Nov - 2018****ENGINEERING DRAWING**

(Common to ECE, EIE, ECom E)

Time: 3 hours

Max. Marks: 70

- Note: 1. Question Paper consists of two parts (**Part-A** and **Part-B**)  
 2. Answering the question in **Part-A** is Compulsory  
 3. Answer any **FOUR** Questions from **Part-B**

**PART -A**

1. a) Draw the projections of a point 'G' on the HP and 40mm in front of the VP. (2M)
- b) Draw the projections of a straight line EF of length 90mm when it contained by profile plane with its end E 20mm above the HP while the other on the VP. (4M)
- c) A rectangular plane 60X40 is parallel to the HP and perpendicular to the VP. Draw its projections when its longest edge is parallel to the VP. (4M)
- d) An orthographic front view of right regular solid appears as 40mm square in standard position. Develop its corresponding isometric view. (4M)

**PART -B**

2. a) Draw the major axis of an ellipse is 120 mm long and the foci are at a distance of 20 mm from its ends. Draw the ellipse, One-half of it by arc of circles method and the other half by rectangle method. (7M)
- b) Draw a plain scale of R.F 1:40 to read Metres and Decimetres and long enough to measure up to 8 m. Show lengths of 4:3 m and 6:2 m on this scale. (7M)
3. a) Draw the projections of the following points, keeping the projectors 25 mm apart: (7M)  
 P- in the HP and 25 mm behind the VP.  
 Q- 45 mm above H.P and 30 mm in front of the VP.  
 R- in the VP and 50 mm above HP.  
 S- 30 mm below the HP and 35 mm behind the VP.  
 T- in both the HP and the VP.
- b) A line AB 45mm long is parallel to V.P and inclined at an angle of  $30^0$  to H.P. The end A is 25mm above H.P and 30mm in front of V.P. Draw the projections of the line. (7M)



4. A line AB 70 mm long has its end A at 20 mm above the HP and 25 mm in front of the VP. Its front view and top view measures 50 mm and 60 mm respectively. Draw the projections of the line and determine its inclinations with the HP and the VP. Show traces also. (14M)
5. a) Draw the projections of a regular pentagon 40 mm side having its surface inclined at  $30^\circ$  to the VP and a side parallel to VP and inclined at an angle of  $60^\circ$  with the HP. (7M)
- b) Draw the projections of a regular pentagon of 30 mm side, with its surface making an angle of  $50^\circ$  with the HP. One of the sides of the pentagon is parallel to HP, and 15 mm away from it. (7M)
6. a) A hexagonal pyramid of base 30mm and axis 60mm long has its axis is parallel to and 50mm above the HP its base is parallel to the VP and an edge of the base is inclined at  $45^\circ$  to the HP. Draw its projections. (7M)
- b) Draw the projection of a cone, base 75 mm diameter and axis 100 mm long, lying on the HP on one of its generators with axis parallel to the VP. (7M)
7. Draw the isometric view of the following orthographic projections. (14M)

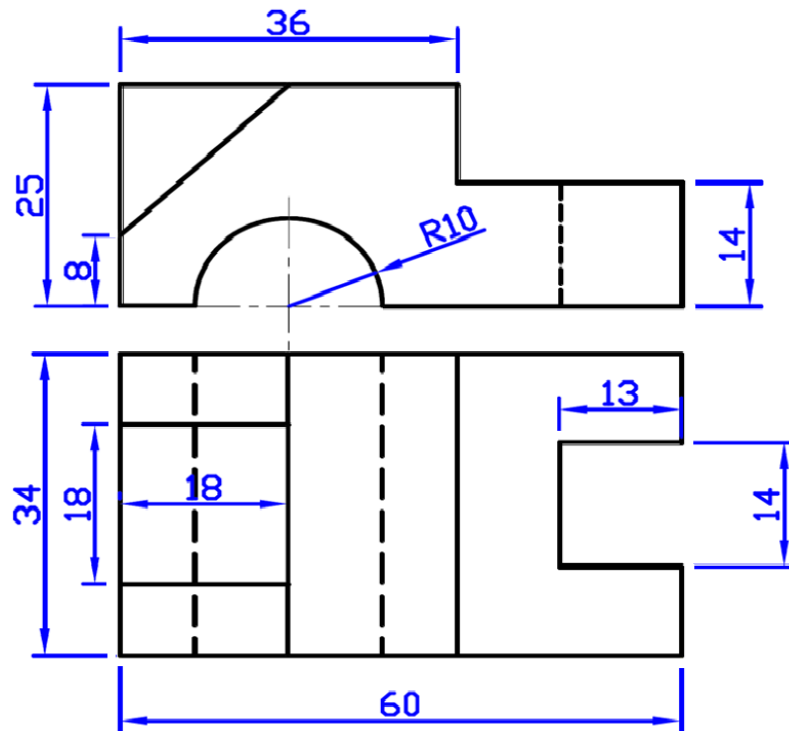

2 of 2



**I B. Tech I Semester Regular/Supplementary Examinations, Oct/Nov - 2018**  
**ENGINEERING DRAWING**  
(Common to ECE, EIE, ECom E)

Time: 3 hours

Max. Marks: 70

- Note: 1. Question Paper consists of two parts (**Part-A** and **Part-B**)  
2. Answering the question in **Part-A** is Compulsory  
3. Answer any **FOUR** Questions from **Part-B**
- ~~~~~

**PART -A**

1. a) Write the following caption as per BIS lettering "SACRIFICE IS A SECTRET OF SUCSESS". (2M)
- b) Draw the projections of a straight line EF of length 70mm when it contained by profile plane with its end E 25mm above the HP while the other 30mm in front of the VP. (4M)
- c) Draw the projection of an equilateral triangular plane with the length of its side 40mm when perpendicular to both the planes and one side parallel to the HP. (4M)
- d) What is the front view a hexagonal pyramid of length of its base 30mm when it is standing on the VP with an edge parallel to the HP. (4M)

**PART -B**

2. a) A plot of land is in the shape of a rectangle of 110 m X 65 m. Inscribe an elliptical fish pond on it. (7M)
- b) Construct a vernier scale of 1:40,000. Showing kilometers, hectometers and decameters and land enough to measure 5 km. Mark distances of 2.31 km and 3.92 km on the scale. (7M)
3. a) A line UV 60 mm length, 25 mm above HP and on VP; the end A is on left profile plane. (7M)
- b) A point A is 20mm above HP and in the first quadrant. Its shortest distance from the reference line XY is 40mm. Draw the projections of the point and determine its distance from VP. (7M)



4. a) A 120 mm long line PQ is inclined at  $45^{\circ}$  to the HP and  $30^{\circ}$  to the VP. A point m on the line is at a distance of 40 mm from p and its front view is 50 mm above the xy line and the top view is 35 mm below the xy line, Draw its projection. Locate the traces. (7M)
- b) A line AB of 60mm long is parallel to and 20 in front of the VP. The ends A and B of the line are 10 and 50mm above the HP respectively. Draw the projections of the line and determine its inclination with HP, locate the traces of the line. (7M)
5. a) A pentagon of 30 mm sides, has one of its corners on HP and its plane is inclined at  $65^{\circ}$  to VP and perpendicular to HP. Draw its projections. (7M)
- b) A square pyramid of side of base 40 mm and height 70 mm is resting on one of its slant edges on HP such that the top view of the axis is inclined to VP at  $30^{\circ}$ . Draw its projection. (7M)
6. a) Draw the projections of a cone, base 60 mm diameter and axis 90 mm long, lying on VP on one of its generators with the axis parallel to HP. (7M)
- b) A square Pyramid base 40 mm side and axis 75 mm long is placed on the ground on one of its slant edges. So that the vertical plane passing through that edge and axis makes an angle of  $30^{\circ}$  with the VP. Draw its three Views. (7M)
7. a) Draw the three orthographic views of a following pictorial projection. (14M)

