



C09-M-407

3507

BOARD DIPLOMA EXAMINATION, (C-09)

OCT/NOV—2016

DME—FOURTH SEMESTER EXAMINATION

PRODUCTION DRAWING

Time : 3 hours]

[Total Marks : 60

PART—A

5×4=20

Instructions : (1) Answer **all** questions.

(2) Each question carries **five** marks.

1. Calculate the values of clearance/interference, hole tolerance and shaft tolerance for a basic size of 40 mm and also determine the type of fit for the tolerances indicated as H7/m6.

2. Draw the symbols for the following : 1×5

(a) Flatness

(b) Circularity

(c) Profile of any line

(d) Angularity

(e) Symmetry

/3507

1

[Contd...

WWW.MANARESULTS.CO.IN

3. Write the surface roughness values for the following : 1×5

- (a) Hot rolling
- (b) Cylindrical grinding
- (c) Lapping
- (d) Boring
- (e) Extrusion

4. Give the meaning of the following designations : 1×5

- (a) Hex bolt M20 × 1.5 × 75NL
- (b) Stud B M20 × 60
- (c) Taper key 15 × 10 × 70
- (d) Splines 8 × 23 × 26
- (e) Ball bearing 205

PART—B

40

Instructions : (1) Answer *any one* question.

(2) Each question carries **forty** marks.

(3) Choose suitable scale.

5. Study the given assembly drawing (Fig. 1) of non-return valve :

- (a) Draw the component drawing (part no. 1, 2, 3, 4) selecting suitable tolerances and fits.
- (b) Prepare the process sheet for 'Body'.

(c) Write the material list for all parts.

(d) Incorporate proper limit, fit and tolerances on components and mention the surface finish on them. 25+5+5+5=40

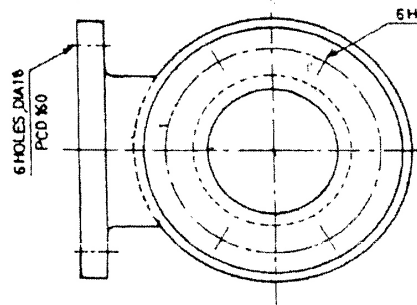
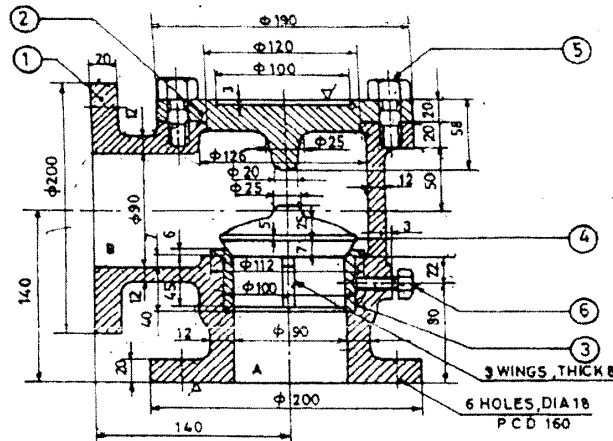

NON-RETURN VALVE

NO	NAME	Qty
1	BODY	1
2	COVER	1
3	VALVE SEAT	1
4	VALVE	1
5	STUD WITH NUT	6
6	SETScrew M10x28	1

Fig. 1

6. Study the given assembly drawing (Fig. 2) of lathe tail-stock :

- (a) Draw the component drawing for parts 1, 2 and 6.
- (b) Indicate geometrical tolerances wherever needed for parts 1, 2 and 6.
- (c) Indicate the recommended surface roughness values on parts 1, 2 and 6.
- (d) Prepare the process sheet for Barrel. 25+5+5+5=40

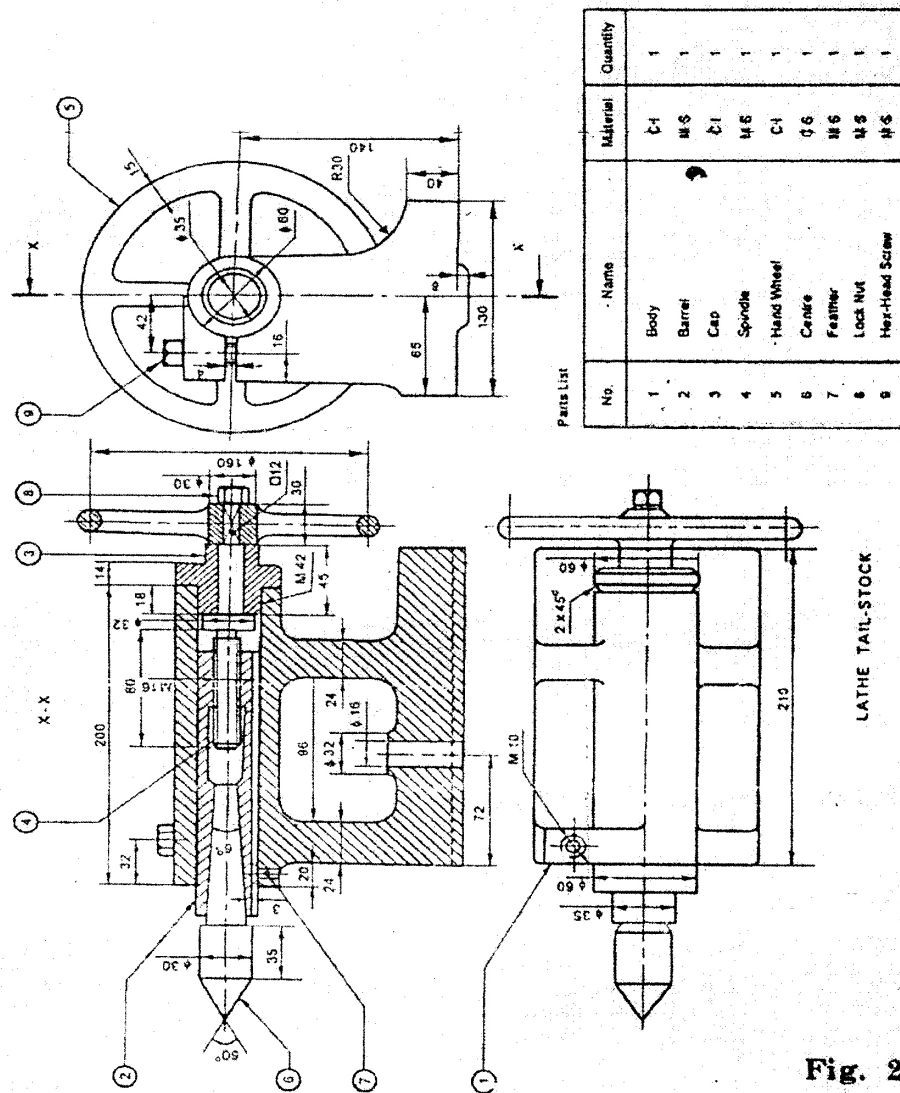

Fig. 2
