



C-14-CHPP/EE-107

4044

BOARD DIPLOMA EXAMINATION, (C-14)

APRIL/MAY—2015

DEEE—FIRST YEAR EXAMINATION

ENGINEERING DRAWING

Time : 3 hours]

[Total Marks : 60

PART—A

5×4=20

Instructions : (1) Answer **all** questions.

(2) Each question carries **five** marks.

(3) All dimensions are in mm.

1. Write the following in 10 mm size single stroke vertical capital lettering :

“ALL THAT GLITTERS IS NOT GOLD”

2. Redraw the following figure and dimension it as per SP:46-1988 by using unidirectional system :

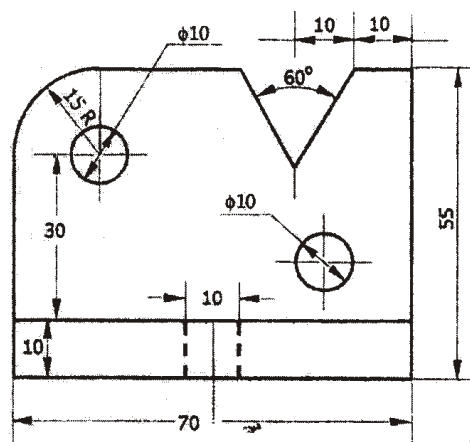

3. Draw an ^{*} octagon of side 4 cm by general method.
4. Draw the auxiliary view of the object shown below :

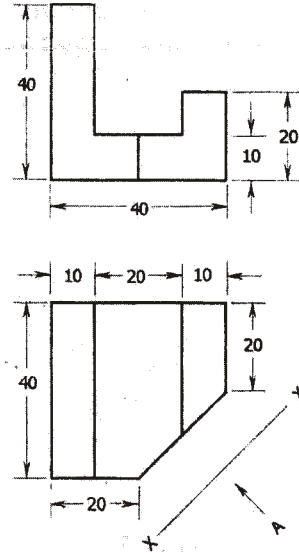

PART—B

10×4=40

Instructions : (1) Answer any **four** questions.

(2) Each question carries **ten** marks.

5. Draw an involute on a pentagon of side 25 mm.
6. A pentagonal prism, side of base 25 mm and axis 60 mm long rests on HP with one of its edges such that the base containing that edge makes an angle of 45° with HP and its axis is parallel to VP. Draw its projections.
7. Draw the orthographic views of the block :

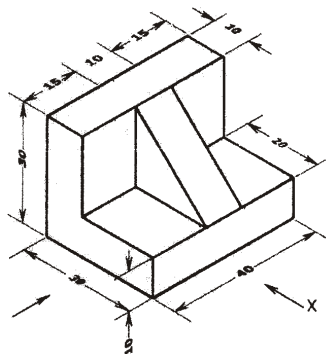

8. Draw the isometric view for the object whose orthographic views are given :

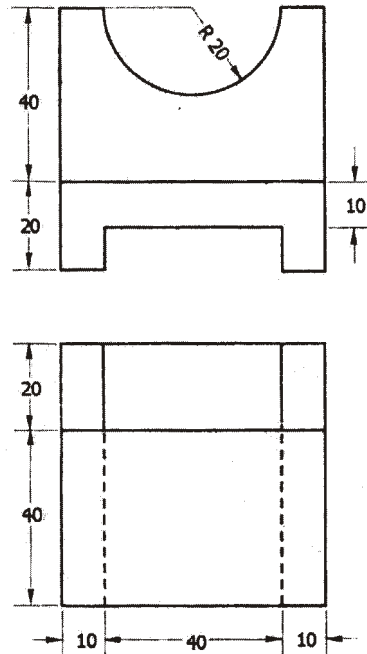

9. A right circular cylinder of diameter 60 mm and height 80 mm rests on its base such that its axis is inclined at 50° to HP, and parallel to VP. A cutting plane parallel to HP and perpendicular to VP cuts the axis at a distance of 40 mm from the bottom face. Draw the front view and sectional top view.
10. A cylinder of base 50 mm diameter and axis 100 mm long is resting on its base on HP. It has a circular hole of 30 mm diameter, drilled centrally through such that the axis of the hole is perpendicular to VP and bisects the axis of the cylinder at right angles. Develop the lateral surface of the cylinder.
