

4457

*
BOARD DIPLOMA EXAMINATION, (C-14)
MARCH/APRIL-2019
DECE - FOURTH SEMESTER EXAMINATION
NETWORK ANALYSIS

Time: 3 Hours]

[Max. Marks : 80

PART - A

10x3=30M

- Instructions:** 1) Answer **all** the questions. Each question carries **three** marks.
 2) Answer should be brief and straight to the point and shall not exceed five simple sentences.

- 1) State the ohm's law and mention its limitations.
- 2) Give the formulae for co-efficient of coupling(k) and find K if $L_1 = 0.8H$, $L_2 = 0.2H$, $M = 0.36H$.
- 3) Draw the dual of the given network shown below.

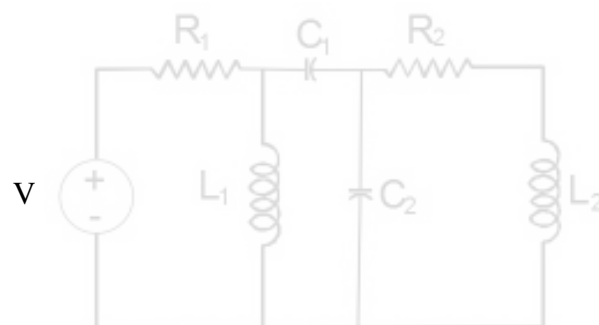

*

- 4) How many no. of independent mesh equations and nodal equations are required for the circuit having 7 branches and 3 nodes?
- 5) State the Norton's theorem and Draw its equivalent.
- 6) Obtain the Star equivalent circuit for the Delta connected shown in figure below.

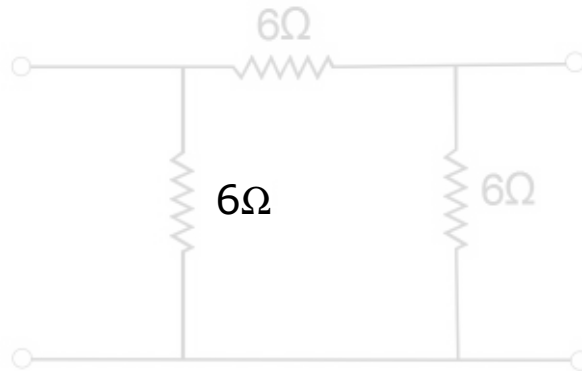

- 7) What is the time constant for given network?

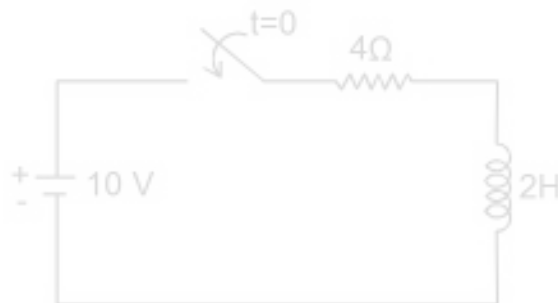

- 8) Give the conditions for symmetry in case of
 - (i) Z-parameters
 - (ii) Y-parameters
 - (iii) h-parameters.
- 9) Define the characteristic impedance and propagation constant.
- 10) List the applications of equalizer circuit.

*

*

PART - B

10x5=50M

Instructions: 1) Answer any five questions. Each question carries ten marks.

2) Answer should be comprehensive and the criterion for valuation is the content but not the length of the answer.

11) (a) State Kirchoff's current law and Kirchoff's voltage law. (4M)

(b) For the given network shown below (6M)

(i) If $R_1=R_2=\infty$, then find I_1 and V_1

(ii) If $R_1=0$, then find I_1 and V_1

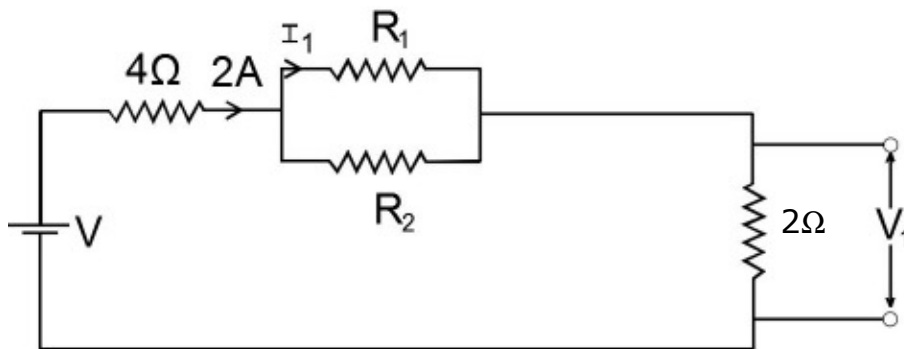

12) Determine the power absorbed by the 5Ω resistor in the circuit shown by using Mesh analysis.

*

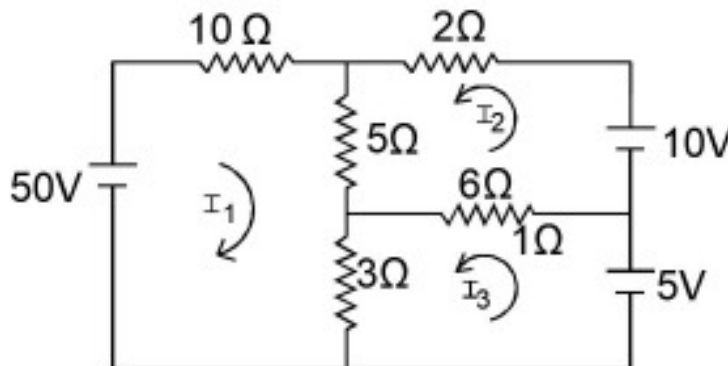

*

13) Determine the voltages V_1 in the given network using nodal voltage analysis?.

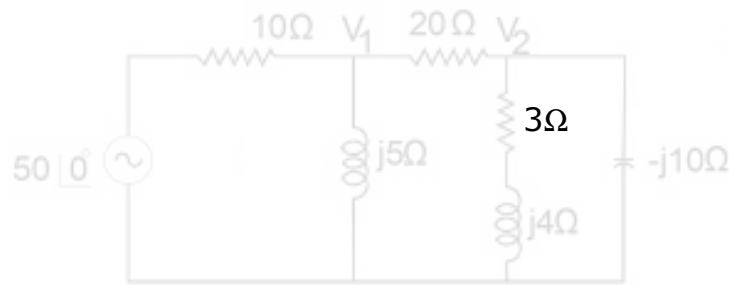

14) (a) Determine the Norton's equivalent. (5M)

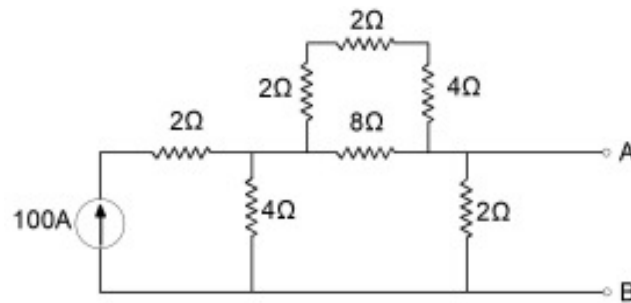

(b) Find the thevenins equivalent. (5M)

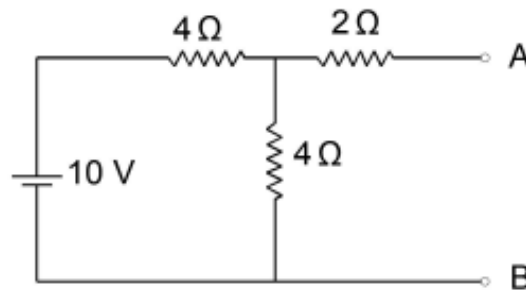

15) (a) Determine the value of R required for the Maximum power delivered to the load. (5M)

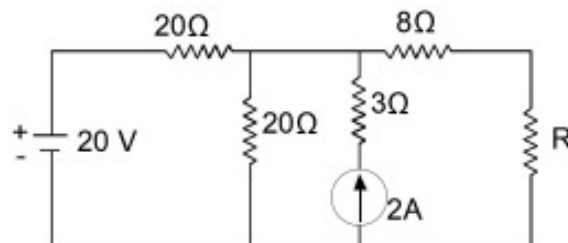

(b) State the following theorems. (5M)

(i) Reciprocity theorem

(ii) Super position theorem.

16) (a) Find the Z-parameters for a given T- network. (4M)

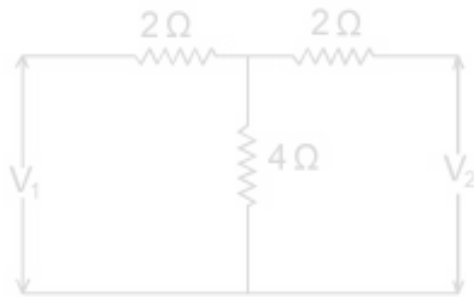

(b) Find the Y-parameters for a given T-network (6M)

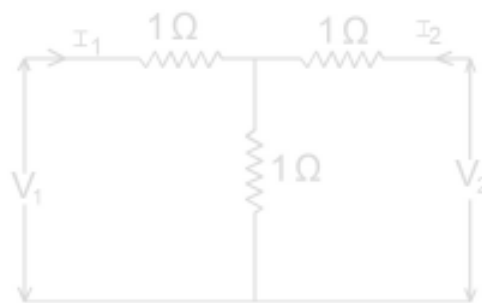

17) Determine the complete expression for the current when the switch is closed at $t=0$

*

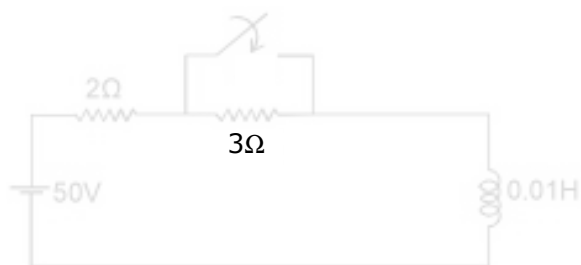

18) Design a LPF for T-section having cut off frequency of $2kHz$ to operate with a terminated load Resistance of 300Ω .

*

* * *