

6426
BOARD DIPLOMA EXAMINATION
JUNE - 2019
 * **DIPLOMA IN CIVIL ENGINEERING**
QUANTITY SURVEYING
FOURTH SEMESTER EXAMINATION

Time: 3 Hours

Total Marks: 80

PART - A **(3m x 10 = 30m)**

Note 1: Answer all questions and each question carries 3 marks

2: Answers should be brief and straight to the point and shall not exceed 5 simple sentences

1. Prepare the approximate estimate of a proposed construction of a building having plinth area of 110m^2 and cost per unit area is RS.1900/-
2. State the units of measurements of the following items
 - a) D.P.C of Specified width & thickness
 - b) R.C.C
 - c) Rough Stone pitching
3. calculate the length of the members DC, EG and DG for the truss shown in the figure below

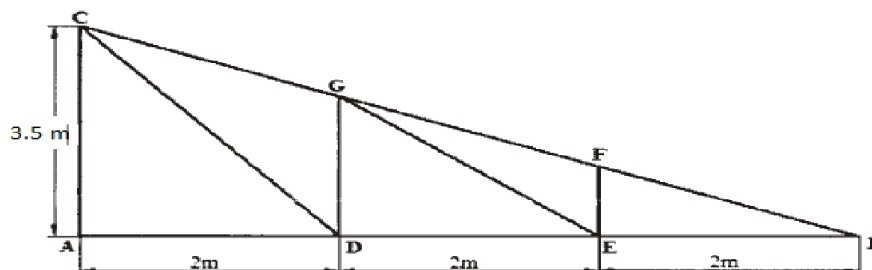

4. Calculate the quantity of sand required for filling in basement for the room of size $4.5\text{ m} \times 3.5\text{ m}$, if the height and thickness of the basement are 0.65 m and 0.45 m respectively. The thickness of the wall is 0.3 m .
5. Define the terms
 - A) Analysis of rates
 - B) Standard data book
6. Calculate the weight of two legged stirrup of 8mm dia. for simply supported beam of size $300 \times 550\text{mm}$. Concrete cover at all sides is 40mm and unit weight of rod is 0.39 Kg/m
7. Find the volume of earth work in an embankment of length 2.5km , top width of road is 7.5m and depth is 2m , side slope $1.5:1$

8. The cross-section of an abutment is shown in the figure below.
 Calculate the quantities for the following items for the length of 15 m
 (a) CC (1 : 3 : 6) for foundation
 (b) RR masonry in CM (1:6)

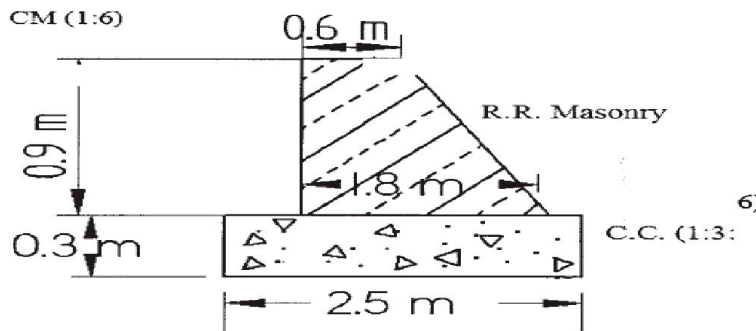

9. List the purpose of valuation

10. The cost of a newly constructed building including all provision is Rs 10, 00,000/-. Calculate monthly rent, if the reasonable interest on capital is 8%

PART - B (10m x 5 = 50m)

Note 1: Answer any five questions and each carries 10 marks

2: The answers should be comprehensive and the criteria for valuation is the content but not the length of the answer

11. Prepare the detailed estimate for the following items of work from the given Fig
 (a) CC bed (1:4:8) in foundation
 (b) Brick Masonry in CM (1:5) for Basement
 (c) R.C.C roof slab (1:2:4) 150 mm thick

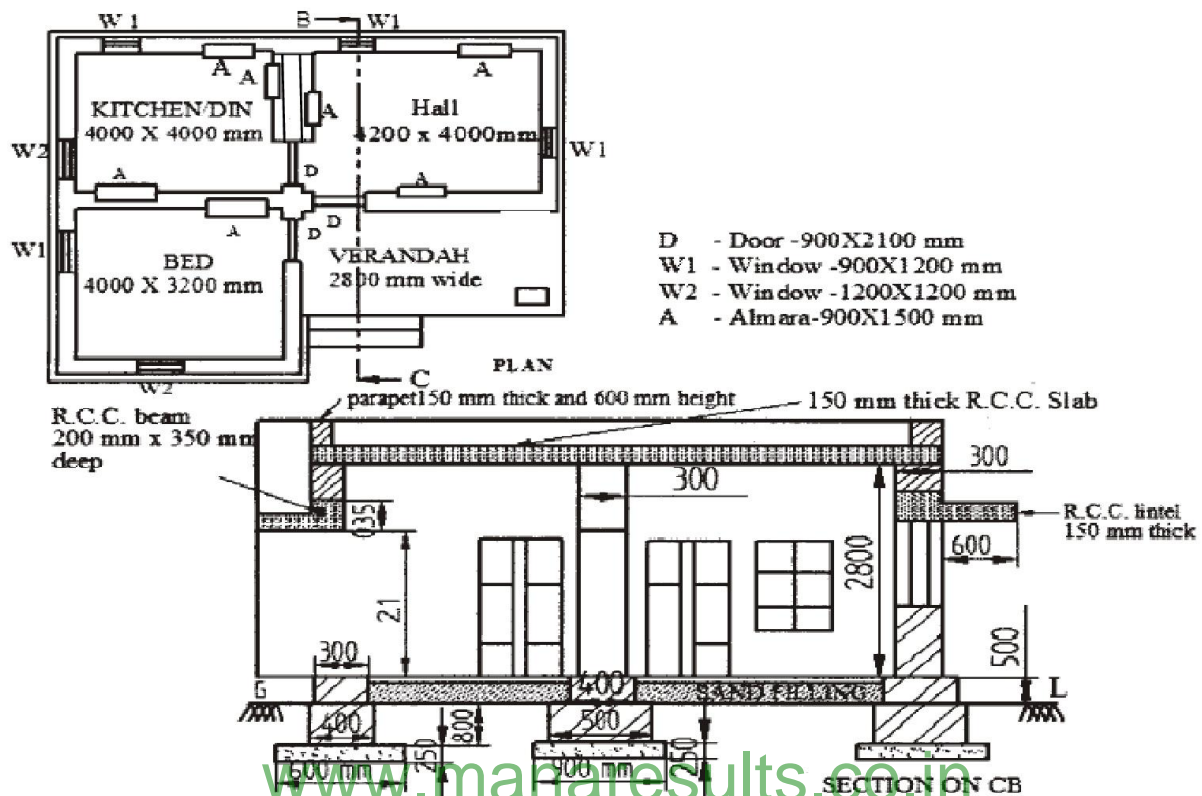

12. Prepare the detailed estimate for the following items of work from the given Fig

(a) Earthwork Excavation for foundation

(b) R.R Masonry in footings

(c) Brick Masonry in CM (1:6) for super structure excluding parapet and without deductions for doors, windows and lintels

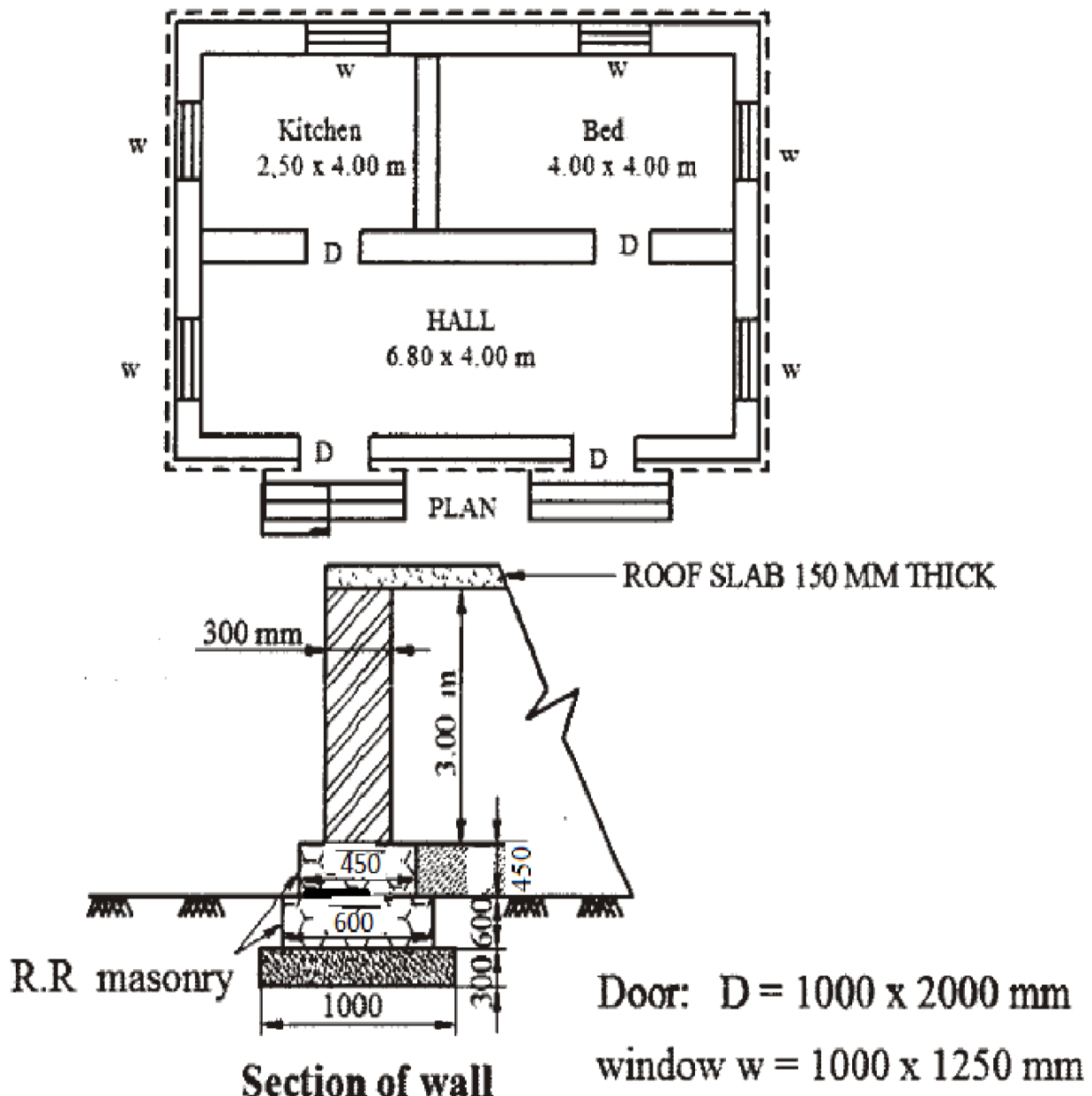

13. Prepare the data sheet and calculate the cost for the following items of work.

(a) RR masonry with CM (1: 8) unit—1 m³

1.05 m³ Rough stone

0.34 m³ CM (1: 8)

1.8 no. Mason

2.8 nos. Men mazdoor

LS Sundries

(b) Pointing to RR masonry in CM (1: 5) unit—10 m²

0.09 m³ CM (1: 5)

2.28 nos. Mason

0.5 nos. Men mazdoor

1.1 nos. Women mazdoor

LS Sundries

Lead statement of materials :

Sl.No	Materials	Rate at source(in Rs)	Leads(in km)	Conveyancecharges/km
1	Rough stone	320/ m ³	15 km	4.00/m ³ /Km
2	Sand	95/ m ³	10 km	3.00/ m ³ /Km
3	Cement	2,500/10 kN	(1 tonne)	At site

Labour charges :

Mason Rs 225.00/day

Men mazdoor Rs180.00/day

Women mazdoor Rs 180.00/day

Mixing charges for CM Rs 40.00/m³

*

*

14. Prepare a data sheet and calculate the cost of the items given below

(i) Plain cement concrete (1:4:8) for foundation - 1m^3

(ii) Brick work in CM (1:5) using country bricks - 1m^3

Materials and labour required for 1m^3

PCC (1:4:8)

0.92 m^3 HBG metal

... m^3 sand

... m^3 cement

0.06 nos. mason 1st class

0.14 nos. mason 2nd class

1.80 nos. men mazdoors

1.4 nos. women mazdoors

L.S sundries

Brickwork in CM (1:5)

600 nos. country bricks

0.38 m^3 CM (1:5)

0.42 nos. mason 1st class

0.98 nos. mason 2nd class

0.70 nos. men mazdoors

2.10 nos. women mazdoors

L.S sundries

Labour charges per day and cost of materials at site:

HBG metal 40 mm size - Rs.450/cum

Sand - Rs.250/cum

Cement - Rs.3400/10 kN

Country bricks - Rs 6000/1000 nos.

Mason 1st class = Rs.350/-

Mason 2nd class = Rs.300/-

Men mazdoor = Rs.240/-

Women mazdoor = Rs.200/-

Hand maxing charges of CM per m^3 = Rs.100/-

15. The road has following data

chainage	100	120	140	160	180	200	220	240	260	280	300	320	340
R.L of ground	149.5	148.30	150.0	149.95	148.55	149.9	150.6	150.9	151.4	150.7	151.1	151	150.60
R.L of formation	150.00	RISING GRADIENT 1 IN 200					FALLING GRADIENT 1 IN 400						

The top width is 10m and the side slope is 1:5:1, Assuming that the slope of the ground in transverse direction is level. Calculate volume of earth work by trapezoidal rule

*

Calculate the following quantities for a septic tank shown in figure :

16. (a) Cement concrete 1 : 4 : 8 for foundation
(b) 2nd class brickwork in CM (1 : 6)

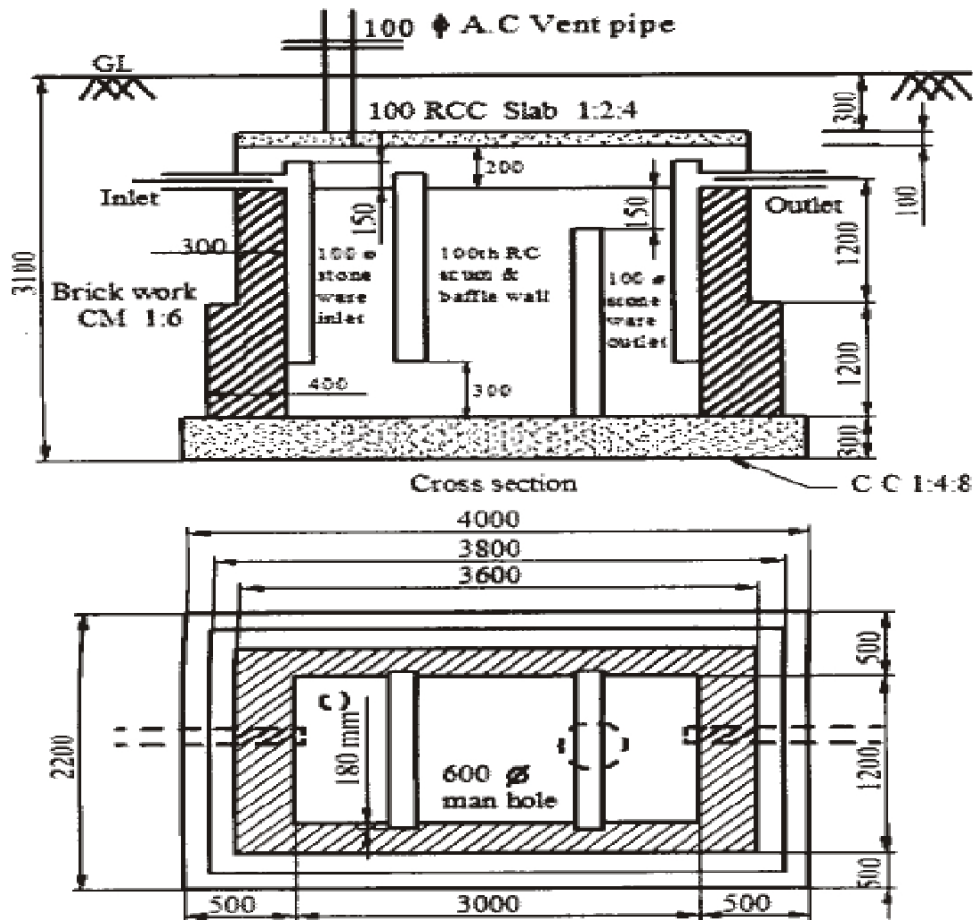

17. Prepare the detailed estimate of the following items of work for a water bound macadam road as shown in the figure below for a length of 200 m :
- Collection and supply of gravel for shoulders of loose thickness 150 mm
 - Collection and supply of 65 mm HBG metal for base course of loose thickness 150 mm
 - Spreading of 40 mm HBG metal for wearing course of loose thickness 100 mm

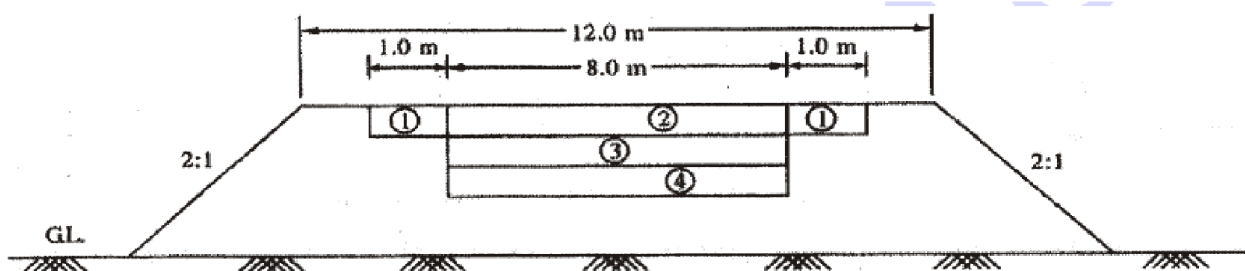

18. Residential building Construction 12 year ago is situated on plot whose total area is 500m^2 . The plinth area of the building is 300m^2 . The present cost of construction of the building is RS 3,30,00/- and the cost of the land is RS 210/- m^2 . The rate of depreciation for the value of the building is 2%. Calculation to total value of property