

Q. 1 – Q. 25 carry one mark each.

- Q.1 Let \mathbf{A} be an $n \times n$ matrix with rank r ($0 < r < n$). Then $\mathbf{Ax} = 0$ has p independent solutions, where p is
 (A) r (B) n (C) $n - r$ (D) $n + r$
- Q.2 The value of $\oint \frac{1}{z^2} dz$, where the contour is the unit circle traversed clockwise, is
 (A) $-2\pi i$ (B) 0 (C) $2\pi i$ (D) $4\pi i$
- Q.3 The double integral $\int_0^a \int_0^y f(x, y) dx dy$ is equivalent to
 (A) $\int_0^x \int_0^y f(x, y) dx dy$ (B) $\int_0^a \int_x^y f(x, y) dx dy$
 (C) $\int_0^a \int_x^a f(x, y) dy dx$ (D) $\int_0^a \int_0^a f(x, y) dx dy$
- Q.4 The magnitude of the directional derivative of the function $f(x, y) = x^2 + 3y^2$ in a direction normal to the circle $x^2 + y^2 = 2$, at the point $(1, 1)$, is
 (A) $4\sqrt{2}$ (B) $5\sqrt{2}$ (C) $7\sqrt{2}$ (D) $9\sqrt{2}$
- Q.5 The figure shows a half-wave rectifier circuit with input voltage $V(t) = 10 \sin(100 \pi t)$ volts. Assuming ideal diode characteristics with zero forward voltage drop and zero reverse current, the average power consumed in watts by the load resistance R_L is _____ W .

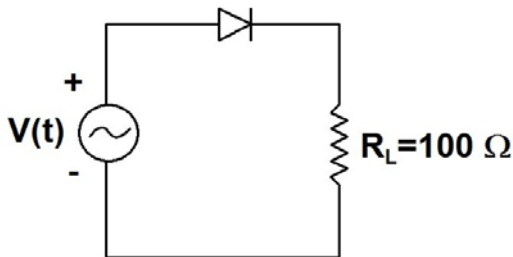

- Q.6 The capacitor shown in the figure is initially charged to +10 V. The switch closes at time $t = 0$. Then the value of $V_C(t)$ in volts at time $t = 10$ ms is _____ V .

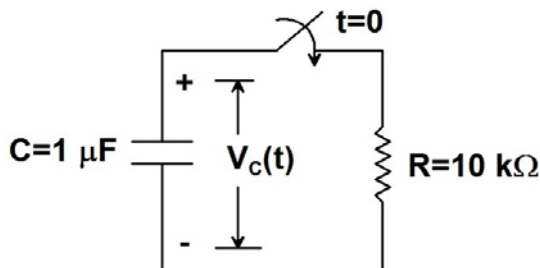

- Q.7 The torque transmitted by a cylindrical shaft is to be measured by using two strain gauges. The angles for mounting the strain gauges relative to the axis of the shaft for maximum sensitivity are
 (A) $\pm 45^\circ$ (B) $\pm 60^\circ$ (C) $\pm 90^\circ$ (D) $\pm 180^\circ$

Q.8 A p-type semiconductor strain gauge has a nominal resistance of 1000Ω and a gauge factor of $+200$ at 25°C . The resistance of the strain gauge in ohms when subjected to a strain of $+10^{-4}$ m/m at the same temperature is _____ Ω .

Q.9 Liquid flow rate is measured using

- (A) a Pirani gauge
- (B) a pyrometer
- (C) an orifice plate
- (D) a Bourdon tube

Q.10 The output voltage of the ideal transformer with the polarities and dots shown in the figure is given by

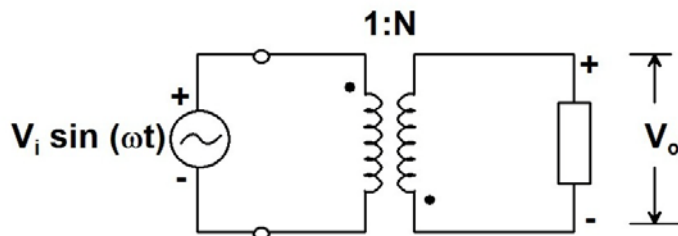

- (A) $NV_i \sin \omega t$
- (B) $- NV_i \sin \omega t$
- (C) $\frac{1}{N} V_i \sin \omega t$
- (D) $-\frac{1}{N} V_i \sin \omega t$

Q.11 A load resistor R_L is connected to a battery of voltage E with internal resistance R_i through a resistance R_s as shown in the figure. For fixed values of R_L and R_i , the value of $R_s (\geq 0)$ for maximum power transfer to R_L is

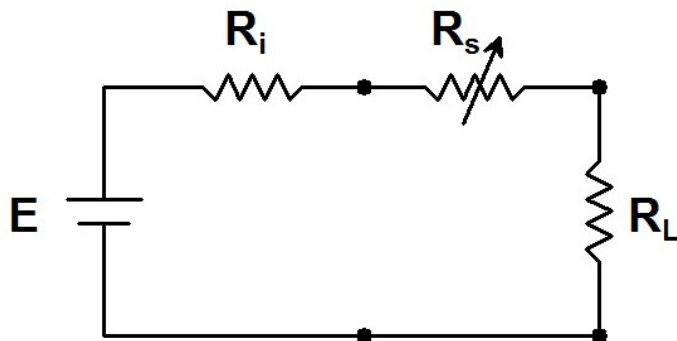

- (A) 0
- (B) $R_L - R_i$
- (C) R_L
- (D) $R_L + R_i$

Q.12 Consider the logic circuit with input signal TEST shown in the figure. All gates in the figure shown have identical non-zero delay. The signal TEST which was at logic LOW is switched to logic HIGH and maintained at logic HIGH. The output

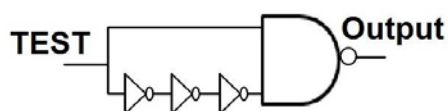

- (A) stays HIGH throughout
- (B) stays LOW throughout
- (C) pulses from LOW to HIGH to LOW
- (D) pulses from HIGH to LOW to HIGH

Q.13 The logic evaluated by the circuit at the output is

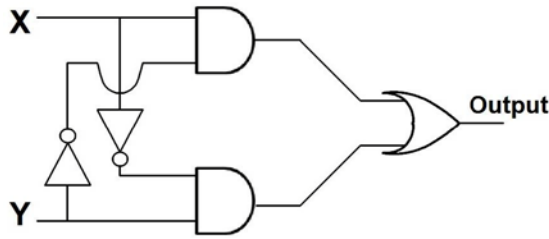

- (A) $X\bar{Y}+Y\bar{X}$ (B) $(\bar{X}+\bar{Y})XY$ (C) $\bar{X}\bar{Y}+XY$ (D) $\bar{X}\bar{Y}+X\bar{Y}+X+Y$

Q.14 In the circuit shown, the switch is momentarily closed and then opened. Assuming the logic gates to have equal non-zero delay, at steady state, the logic states of X and Y are

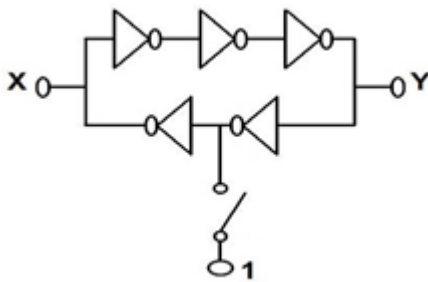

- (A) X is latched, Y toggles continuously (B) X and Y are both latched
 (C) Y is latched, X toggles continuously (D) X and Y both toggle continuously

Q.15 The highest frequency present in the signal $x(t)$ is f_{max} . The highest frequency present in the signal $y(t) = x^2(t)$ is

- (A) $\frac{1}{2}f_{max}$ (B) f_{max} (C) $2f_{max}$ (D) $4f_{max}$

Q.16 The filter whose transfer function is of the form $G(s) = \frac{s^2-bs+c}{s^2+bs+c}$ is

- (A) a high-pass filter (B) a low-pass filter
 (C) an all-pass filter (D) a band-reject filter

Q.17 Let $3 + 4j$ be a zero of a fourth order linear-phase FIR filter. The complex number which is **NOT** a zero of this filter is

- (A) $3 - 4j$ (B) $\frac{3}{25} + \frac{4}{25}j$ (C) $\frac{3}{25} - \frac{4}{25}j$ (D) $\frac{1}{3} - \frac{1}{4}j$

Q.18 Consider the ammeter-voltmeter method of determining the value of the resistance R using the circuit shown in the figure. The maximum possible errors of the voltmeter and ammeter are known to be 1 % and 2 % of their readings, respectively. Neglecting the effects of meter resistances, the maximum possible percentage error in the value of R determined from the measurements, is _____ %.

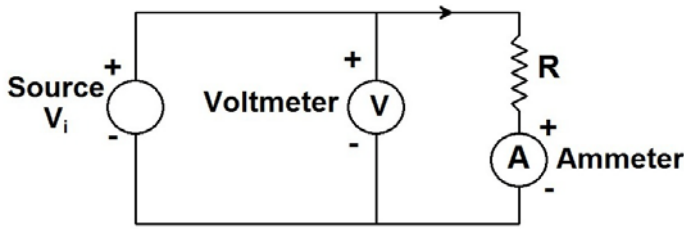

Q.19 The bridge most suited for measurement of a four-terminal resistance in the range of 0.001Ω to 0.1Ω is

- (A) Wien’s bridge
- (B) Kelvin double bridge
- (C) Maxwell’s bridge
- (D) Schering bridge

Q.20 A power line is coupled capacitively through various parasitic capacitances to a shielded signal line as shown in the figure. The conductive shield is grounded solidly at one end. Assume that the length of the signal wire extending beyond the shield, and the shield resistance are negligible. The magnitude of the noise voltage coupled to the signal line is

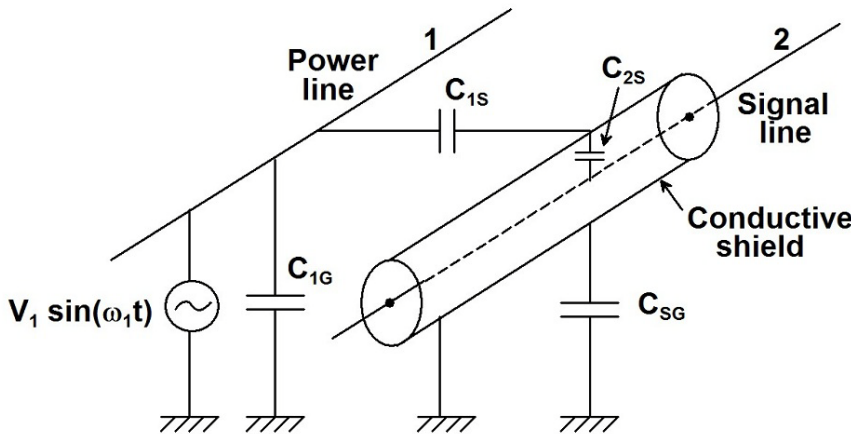

- (A) directly proportional to C_{1G}
- (B) inversely proportional to the power line frequency
- (C) inversely proportional to C_{1S}
- (D) zero

Q.21 A mass-spring-damper system with force as input and displacement of the mass as output has a transfer function $G(s) = 1/(s^2 + 24s + 900)$. A force input $F(t) = 10 \sin(70t)$ newtons is applied at time $t = 0$ s. A beam from an optical stroboscope is focused on the mass. In steady state, the strobe frequency in hertz at which the mass appears to be stationary is

- (A) $5/\pi$
- (B) $15/\pi$
- (C) $35/\pi$
- (D) $50/\pi$

Q.22 A system with transfer function $G(s) = \frac{1}{s^2+1}$ has zero initial conditions. The percentage overshoot in its step response is _____ %.

Q.23 The voltage (E_0) developed across a glass electrode for pH measurement is related to the temperature (T) by the relation

- (A) $E_0 \propto \frac{1}{T^2}$ (B) $E_0 \propto \frac{1}{T}$ (C) $E_0 \propto T$ (D) $E_0 \propto T^2$

Q.24 A light detector circuit using an ideal photo-diode is shown in the figure. The sensitivity of the photo-diode is $0.5 \mu\text{A}/\mu\text{W}$. With $V_r = 6 \text{ V}$, the output voltage $V_o = -1.0 \text{ V}$ for $10 \mu\text{W}$ of incident light. If V_r is changed to 3 V , keeping all other parameters the same, the value of V_o in volts is _____ V.

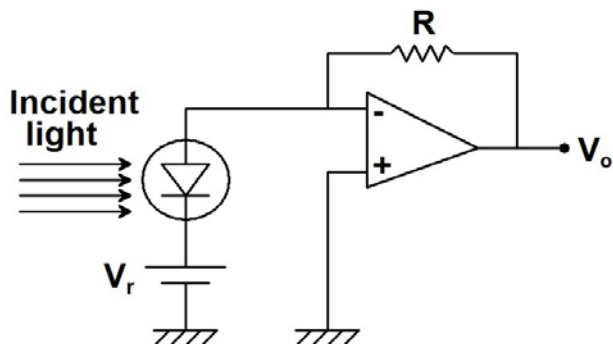

Q.25 An apparatus to capture ECG signals has a filter followed by a data acquisition system. The filter best suited for this application is

- (A) low pass with cutoff frequency 200 Hz
 (B) high pass with cutoff frequency 200 Hz
 (C) band pass with lower and upper cutoff frequencies 100 Hz and 200 Hz for its pass band
 (D) band reject with lower and upper cutoff frequencies 1 Hz and 200 Hz for its stop band

Q. 26 – Q. 55 carry two marks each.

Q.26 The probability that a thermistor randomly picked up from a production unit is defective is 0.1. The probability that out of 10 thermistors randomly picked up, 3 are defective is

- (A) 0.001 (B) 0.057 (C) 0.107 (D) 0.3

Q.27 The probability density function of a random variable X is $p_X(x) = e^{-x}$ for $x \geq 0$ and 0 otherwise. The expected value of the function $g_X(x) = e^{3x/4}$ is _____ .

Q.28 The z-transform of $x[n] = \alpha^{|n|}$, $0 < |\alpha| < 1$, is $X(z)$. The region of convergence of $X(z)$ is

- (A) $|\alpha| < |z| < \frac{1}{|\alpha|}$ (B) $|z| > \alpha$ (C) $|z| > \frac{1}{|\alpha|}$ (D) $|z| < \min [|\alpha|, \frac{1}{|\alpha|}]$

Q.29 The current in amperes through the resistor R in the circuit shown in the figure is _____ A.

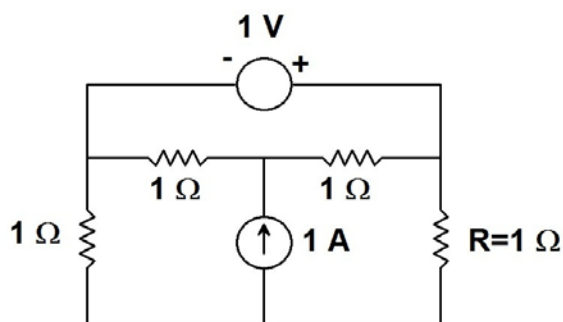

Q.30 The linear I-V characteristics of 2-terminal non-ideal dc sources X and Y are shown in the figure. If the sources are connected to a 1Ω resistor as shown, the current through the resistor in amperes is _____ A.

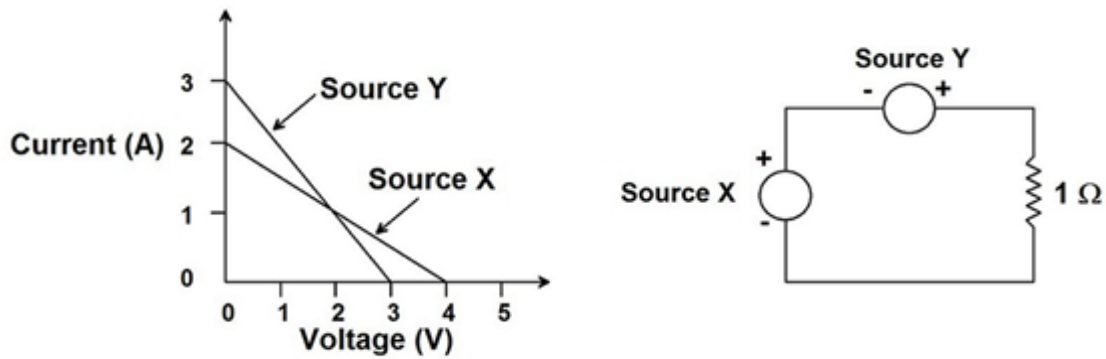

Q.31 Consider the circuits shown in the figure. The magnitude of the ratio of the currents, *i.e.*, $|I_1/I_2|$, is _____ .

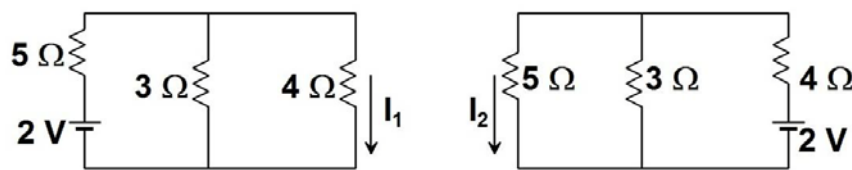

Q.32 The circuit shown in the figure is in series resonance at frequency f_c Hz. The value of V_c in volts is _____ V.

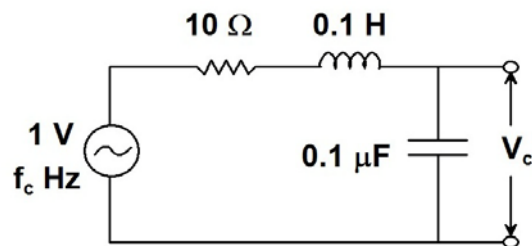

Q.33 The output frequency of an LC tank oscillator employing a capacitive sensor acting as the capacitor of the tank is 100 kHz. If the sensor capacitance increases by 10 %, the output frequency in kilohertz becomes _____ kHz.

Q.34 The Seebeck coefficients, in $\mu\text{V}/^\circ\text{C}$, for copper, constantan and iron, with respect to platinum, are 1.9, -38.3 and 13.3 , respectively. The magnitude of the thermo emf E developed in the circuit shown in the figure, in millivolts is _____ mV.

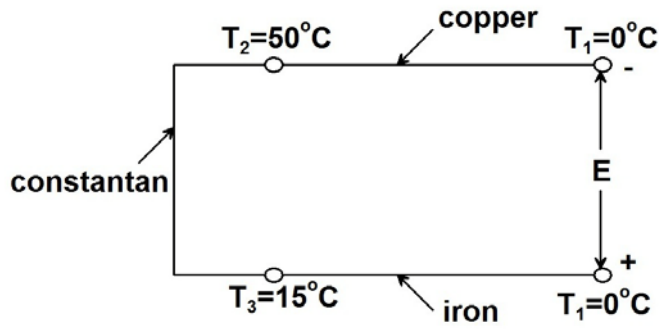

Q.35 In the figure shown, R_T represents a resistance temperature device (RTD), whose characteristic is given by $R_T = R_0(1 + \alpha T)$, where $R_0 = 100 \Omega$, $\alpha = 0.0039 \text{ }^\circ\text{C}^{-1}$ and T denotes the temperature in $^\circ\text{C}$. Assuming the opamp to be ideal, the value of V_o in volts when $T = 100 \text{ }^\circ\text{C}$, is _____ V.

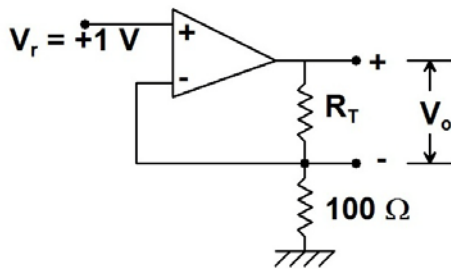

Q.36 In the circuit shown in the figure, it is found that $V_{BE} = 0.7 \text{ V}$ and $V_E = 0 \text{ V}$. If $\beta_{dc} = 99$ for the transistor, then the value of R_B in kilo ohms is _____ $\text{k}\Omega$.

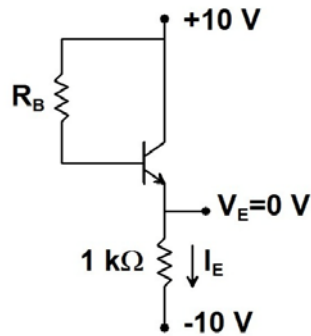

Q.37 An opamp has ideal characteristics except that its open loop gain is given by the expression $A_V(s) = 10^4 / (1 + 10^{-3} s)$. This op-amp is used in the circuit shown in the figure. The 3-dB bandwidth of the circuit, in rad/s, is

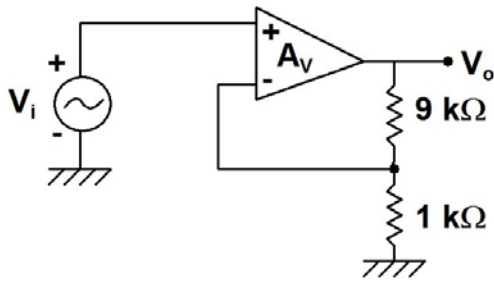

- (A) 10^2 (B) 10^3 (C) 10^4 (D) 10^6

Q.38 In the circuit shown, the voltage source $V(t) = 15 + 0.1 \sin(100t)$ volts. The PMOS transistor is biased such that it is in saturation with its gate-source capacitance being 4 nF and its transconductance at the operating point being 1 mA/V. Other parasitic impedances of the MOSFET may be ignored. An external capacitor of capacitance 2 nF is connected across the PMOS transistor as shown. The input impedance in mega ohm as seen by the voltage source is _____ MΩ.

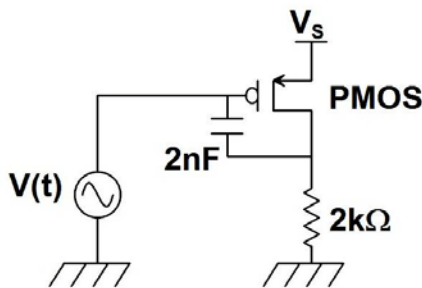

Q.39 An ADC is interfaced with a microprocessor as shown in the figure. All signals have been indicated with typical notations. Acquisition of one new sample of the analog input signal by the microprocessor involves

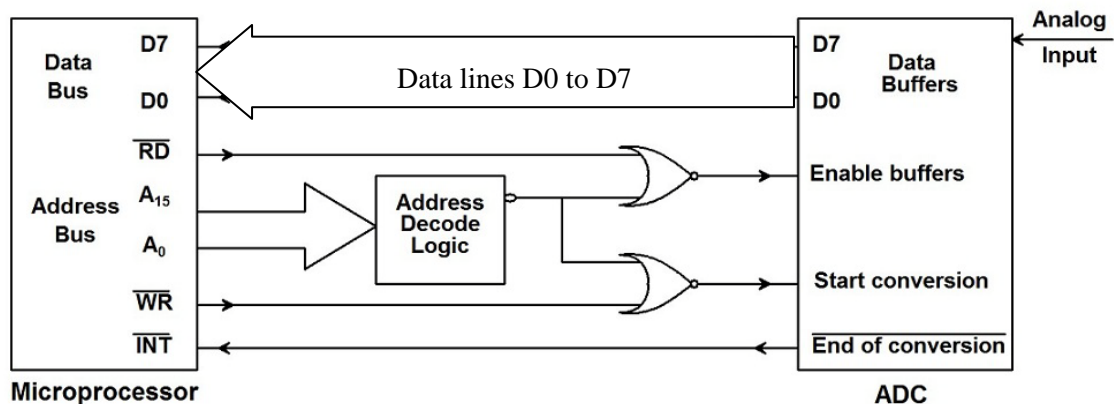

- (A) one READ cycle only
 (B) one WRITE cycle only
 (C) one WRITE cycle followed by one READ cycle
 (D) one READ cycle followed by one WRITE cycle

Q.40 The number of clock cycles for the duration of an input pulse is counted using a cascade of N decade counters (DC 1 to DC N) as shown in the figure. If the clock frequency in mega hertz is f , the resolution and range of measurement of input pulse width, both in μs , are respectively,

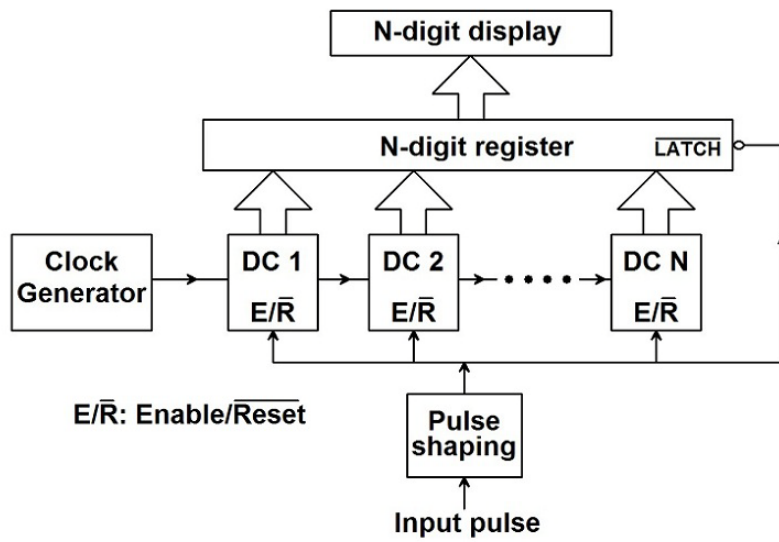

- (A) $\frac{1}{f}$ and $\frac{(2^N-1)}{f}$
- (B) $\frac{1}{f}$ and $\frac{(10^N-1)}{f}$
- (C) $\frac{10^N}{f}$ and $\frac{(10^N-1)}{f}$
- (D) $\frac{2^N}{f}$ and $\frac{(2^N-1)}{f}$

Q.41 For the circuit shown in the figure, the rising edge triggered D-flip flop with asynchronous reset has a clock frequency of 1 Hz. The NMOS transistor has an ON resistance of 1000Ω and an OFF resistance of infinity. The nature of the output waveform is

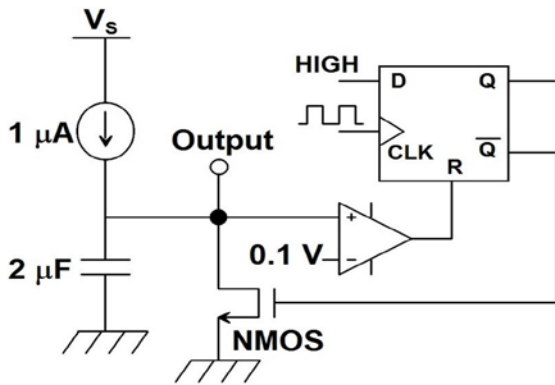

- (A)
- (B)
- (C)
- (D)

Q.42 A transfer function $G(s)$ with the degree of its numerator polynomial zero and the degree of its denominator polynomial two has a Nyquist plot shown in the figure. The transfer function represents

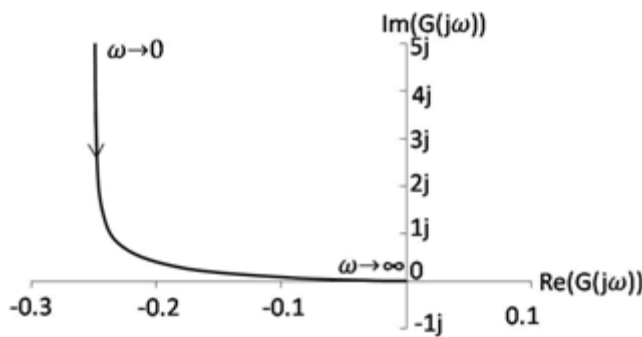

- (A) a stable, type-0 system
- (B) a stable, type-1 system
- (C) an unstable, type-0 system
- (D) an unstable, type-1 system

Q.43 In the circuit shown in the figure, both the NMOS transistors are identical with their threshold voltages being 5 V. Ignoring channel length modulation, the output voltage V_{out} in volt is _____ V.

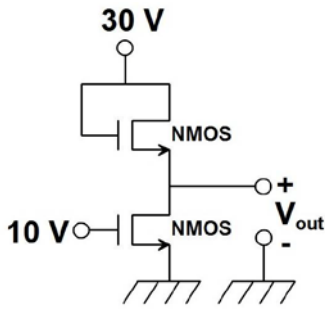

Q.44 The signal $x[n] = \sin(\pi n/6)/(\pi n)$ is processed through a linear filter with the impulse response $h[n] = \sin(\omega_c n)/(\pi n)$ where $\omega_c > \pi/6$. The output of the filter is

- (A) $\sin(2\omega_c n)/(\pi n)$
- (B) $\sin(\pi n/3)/(\pi n)$
- (C) $[\sin(\pi n/6)/(\pi n)]^2$
- (D) $\sin(\pi n/6)/(\pi n)$

Q.45 A signal is band-limited to 0 to 12 kHz. The signal spectrum is corrupted by additive noise which is band-limited to 10 to 12 kHz. Theoretically, the minimum rate in kilohertz at which the noisy signal must be sampled so that the **UNCORRUPTED PART** of the signal spectrum can be recovered, is _____ kHz .

Q.46 Consider a low-pass filter module with a pass-band ripple of δ in the gain magnitude. If M such identical modules are cascaded, ignoring the loading effects, the pass-band ripple of the cascade is

- (A) $1 - (1 - \delta)^M$
- (B) δ^M
- (C) $(1 - \delta)^M$
- (D) $(1 - \delta)^M$

Q.47 The fundamental period of the signal $x(t) = 2 \cos\left(\frac{2\pi t}{3}\right) + \cos(\pi t)$, in seconds, is _____ s.

Q.48 If the deflection of the galvanometer in the bridge circuit shown in the figure is zero, then the value of R_x in ohms is _____ Ω .

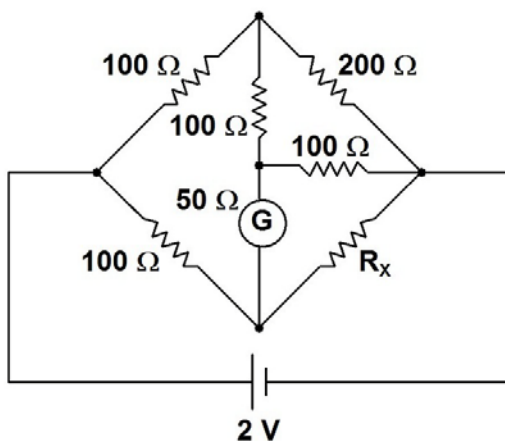

Q.49 In the potentiometer circuit shown in the figure, the expression for V_x is

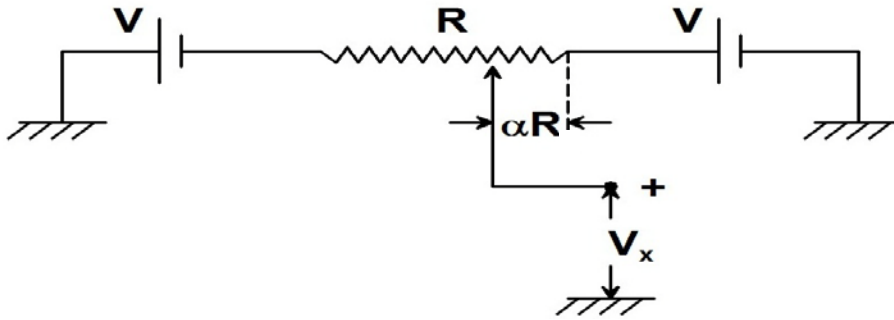

- (A) $(1 - 2\alpha) V$ (B) $(1 - \alpha) V$ (C) $(\alpha - 1) V$ (D) αV

Q.50 The open loop transfer function of a system is $G(s) = \frac{s^2+6s+10}{s^2+2s+2}$. The angles of arrival of its root loci are

- (A) $\pm \frac{\pi}{4}$ (B) $\pm \frac{\pi}{3}$ (C) $\pm \frac{\pi}{2}$ (D) $\pm \frac{5\pi}{6}$

Q.51 A system is represented in state-space as $\dot{\mathbf{x}} = \mathbf{A}\mathbf{x} + \mathbf{B}\mathbf{u}$, where $\mathbf{A} = \begin{bmatrix} 1 & 2 \\ \alpha & 6 \end{bmatrix}$ and $\mathbf{B} = \begin{bmatrix} 1 \\ 1 \end{bmatrix}$. The value of α for which the system is not controllable is _____ .

Q.52 A liquid level measurement system employing a radio-isotope is mounted on a tank as shown in the figure. The absorption coefficient of water for the radiation is 7.7 m^{-1} . If the height of water in the tank is reduced from 100 mm to 90 mm, the percentage change in the radiation intensity received by the detector, neglecting absorption of the radiation by air, is _____ %.

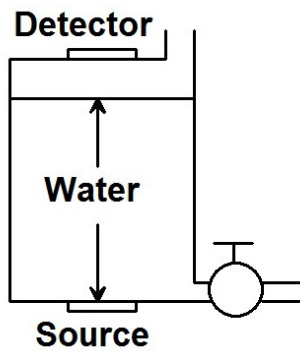

- Q.53 The figure shows a spot of light of uniform intensity 50 W/m^2 and size $10 \text{ mm} \times 10 \text{ mm}$ incident at the exact center of a photo-detector, comprising two identical photo-diodes D_1 and D_2 . Each diode has a sensitivity of 0.4 A/W and is operated in the photoconductive mode. If the spot of light is displaced upwards by $100 \mu\text{m}$, the resulting difference between the photocurrents generated by D_1 and D_2 in micro amperes, is _____ μA .

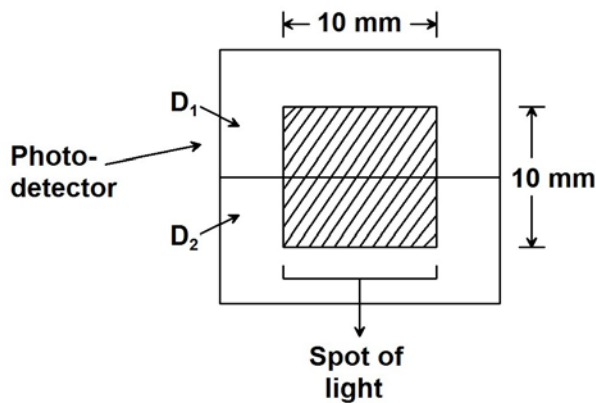

- Q.54 A beam of monochromatic light passes through two glass slabs of the same geometrical thickness at normal incidence. The refractive index of the first slab is 1.5 and that of the second, 2.0. The ratio of the time of passage of the beam through the first to the second slab is _____ .
- Q.55 The resolving power of a spectrometer consisting of a collimator, a grating and a telescope can be increased by
- (A) increasing the angular magnification of the telescope
 - (B) increasing the period of the grating
 - (C) decreasing the period of the grating
 - (D) decreasing the slit-width of the collimator

END OF THE QUESTION PAPER