

R15

Code No: 124DQ

JAWAHARLAL NEHRU TECHNOLOGICAL UNIVERSITY HYDERABAD

B.Tech II Year II Semester Examinations, May - 2017

STRUCTURAL ANALYSIS - I

(Common to CE, CEE)

75

Note: This question paper contains two parts A and B.
Part A is compulsory which carries 25 marks. Answer all questions in Part A.
Part B consists of 5 Units. Answer any one full question from each unit.
and may

PART-

(25 Marks)

- 1.a) Explain what you understand by perfect frame, deficient frame and redundant frame. [2]
- b) Give the relation between number of joints (j) and number of members (m) in a perfect frame in plane and for space structures. [3]
- c) Write down few advantages and disadvantages of arches
- d) Distinguish between a true arch and a corbelled arch.
- e) Write the fixed end moments in a fixed beam, with left support rotated by θ_A in anti clock wise direction. Explain each term mentioned in fixed end moments with sketch. [2]
- f) Explain different types of props with sketches. [3]
- g) Write down the slope deflection equation for a beam element and also explain this method is preferable. [2]
- h) In a member AB, if a moment of 10 kN-m is applied at A, what is the moment carried over to the fixed end B? [3]
- i) Define terms: absolute maximum bending moment and shear force. [2]
- j) Draw the ILD for shear force and bending moment at any section of a simply supported beam. [3]

PART-B

(50 Marks)

2. Determine the forces in the members of the Truss shown in Figure 1. [10]

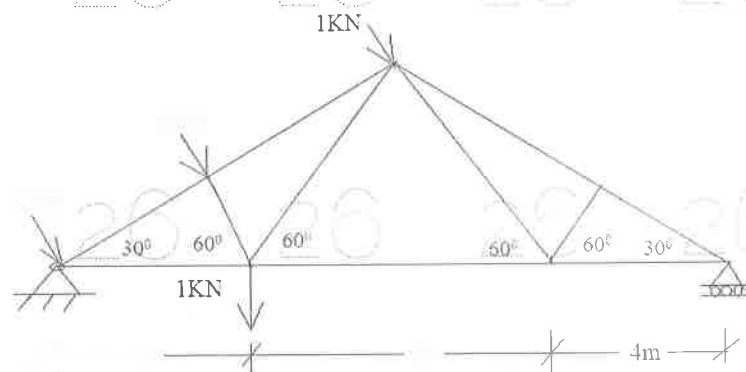

Figure: 1

OR

3. Determine the forces in the members 1(horizontal), 2(vertical) and 3(inclined) of the truss shown in Figure 2 by method of sections. [10]

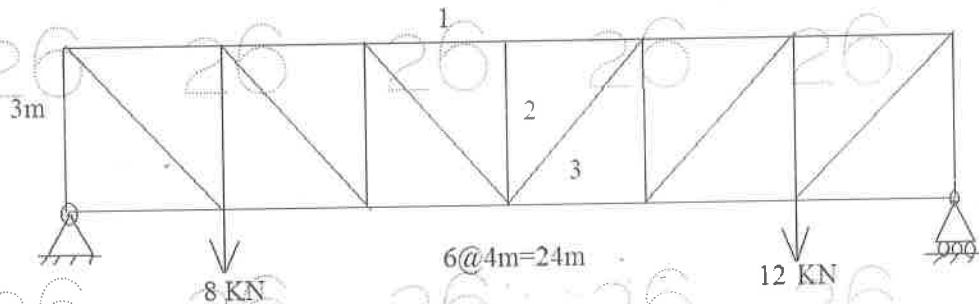

Figure: 2

4. Find the horizontal movement of the roller end of the portal frame shown in Figure 3. Take $E=2 \times 10^5 \text{ N/mm}^2$ and $I=3 \times 10^4 \text{ mm}^4$. [10]

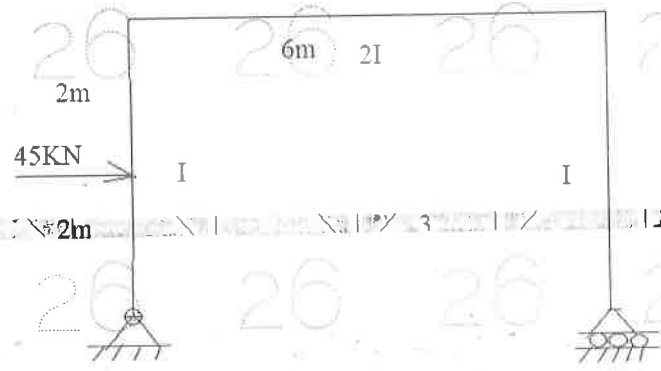

Figure: 3
OR

5. A three hinged parabolic arch of span 'L' has its abutments A and B at depths h_1 and h_2 below the crown C. The arch carries a concentrated load W at the crown. Determine the horizontal thrust, vertical reactions. Draw BMD. [10]
6. Analyse the propped cantilever shown in Figure 4. During loading the fixed end support is rotated 0.002 radians in anti-clockwise direction. Draw BMD. [10]

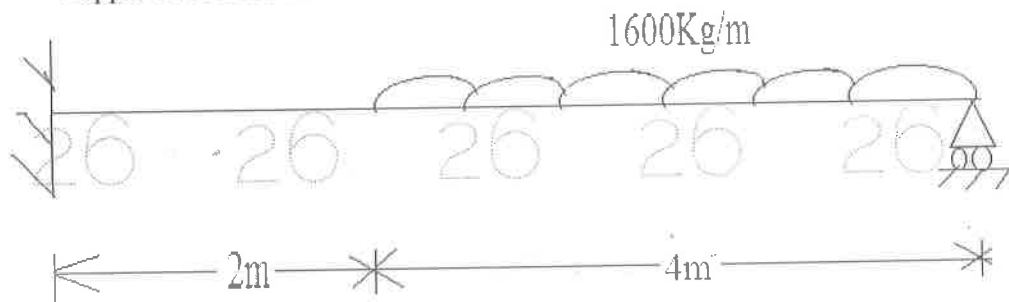

Figure: 4
OR

7. Determine the fixed end moments, reactions and, Draw BMD for the fixed beam shown in Figure 5. [10]

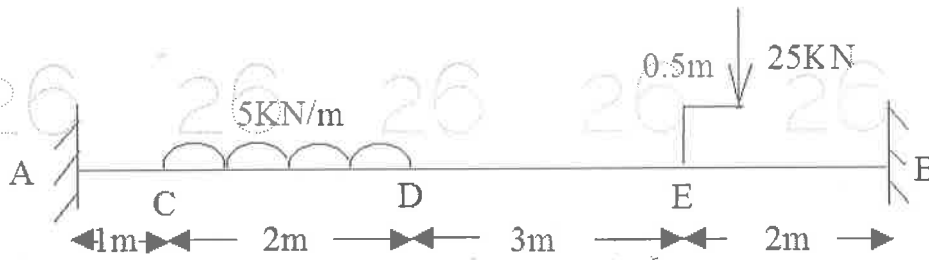

Figure: 5

8. Analyse the portal frame loaded as shown in the Figure 6 and Draw the BMD. The frame is fixed at 'A' and hinged at 'D'. Adopt Moment distribution Method. [10]

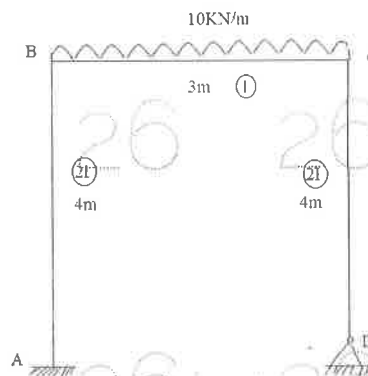

Figure: 6
OR

9. Analyse the portal frame ABCD as shown in Figure 7. The ends A and D are hinged. $EI = \text{constant}$ for the entire frame. Draw the BMD. (Use Slope Deflection Method). [10]

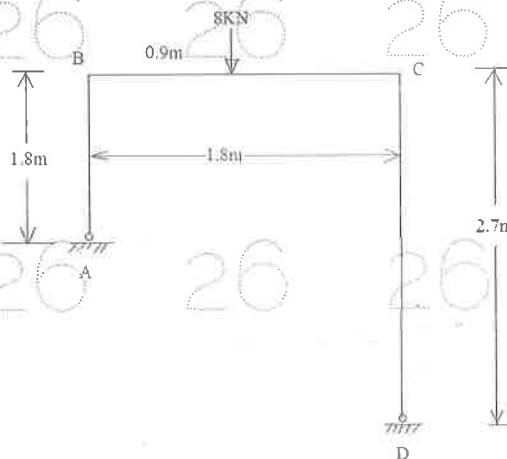

Figure: 7

10. For the beam shown in Figure 8. Draw the ILD for the following:
 a) Reaction V_b at B
 b) Reaction V_a at A
 c) Shear force at D
 d) Bending moment at D, find also maximum values of these quantities due to LL of 20 kN/m. [10]

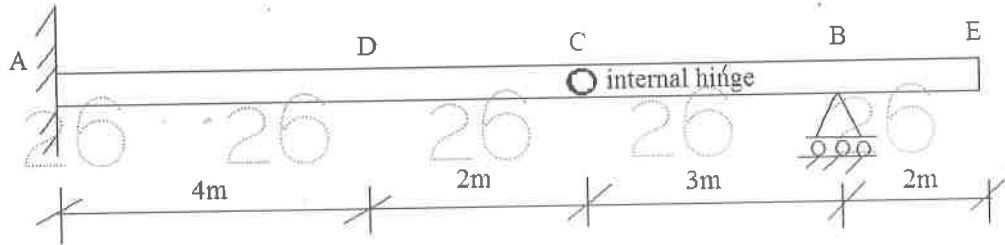

Figure: 8
OR

11. Draw ILD, for top and bottom chords of the warren type truss shown in Figure 9. [10]

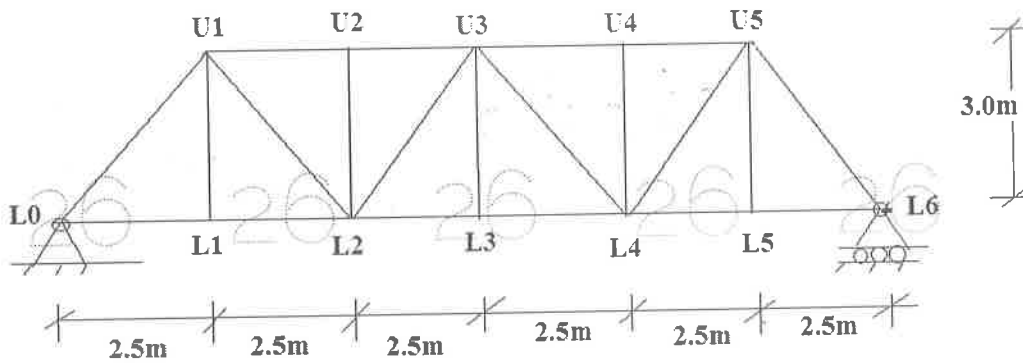

Figure: 9