

Code No: 126EE

**JAWAHARLAL NEHRU TECHNOLOGICAL UNIVERSITY HYDERABAD****B. Tech III Year II Semester Examinations, December - 2017****FINITE ELEMENT METHODS****(Common to AE, MSNT, ME)****Time: 3 hours****Max. Marks: 75****Note:** This question paper contains two parts A and B.

Part A is compulsory which carries 25 marks. Answer all questions in Part A. Part B consists of 5 Units. Answer any one full question from each unit. Each question carries 10 marks and may have a, b, c as sub questions.

**PART - A****(25 Marks)**

- 1.a) State the significance of shape functions. [2]
- b) Define plain strain and plane stress condition and write the D matrix for both the cases. [3]
- c) Write the stiffness matrix for 2-noded beam element. [2]
- d) What are the factors to be considered for selection of nodes? [3]
- e) Specify the strain displacement matrix of CST element and comment on it. [2]
- f) Describe the strain displacement matrix for 3-noded triangular element. [3]
- g) Write the finite element equation used to analyze a two dimensional heat transfer problem. [2]
- h) How do you define two dimensional elements? [3]
- i) What are the ways by which a 3D problem can be reduced to a 2D problem? [2]
- j) What is the difference between static and dynamic analysis with suitable examples? [3]

**PART - B****(50 Marks)**

- 2.a) The following stresses are developed in a plate under plane stress  $\sigma_{xx} = 12\text{Mpa}$ ,  $\sigma_{yy} = -14\text{Mpa}$  and  $\sigma_{xy} = 5\text{Mpa}$ . Determine the strains induced in the plate, assuming that  $E = 209\text{ GPa}$  and  $\nu = 0.3$
- b) Derive  $F=kU$  from the minimum potential energy principle for 2-noded linear element. [5+5]

**OR**

3. A tapered bar of aluminum is having length of 520 cm. The area of cross section at the fixed end is  $82\text{ cm}^2$  and the free end is  $20\text{ cm}^2$  with the variation of the sectional area is linear. The bar is subjected to an axial load of 10 kN at 240 mm from the fixed end. Calculate the maximum displacement and stress developed in the bar? [10]

4. For the pin-jointed truss structure as shown in figure 1 below, determine global stiffness matrix, nodal displacements and element stresses. [10]

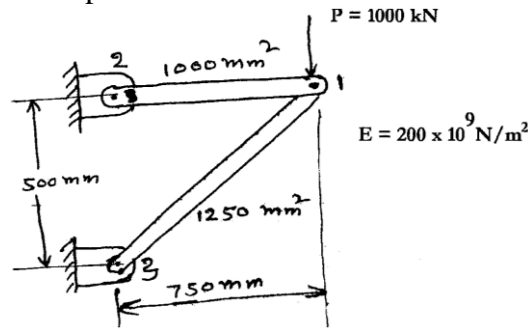

Figure 1

OR

- 5.a) Write about different boundary considerations in beams in detail.  
 b) What is a constant strain triangular element? State its properties and applications in detail. [5+5]

- 6.a) The nodal coordinates of the triangular element as shown in figure 2. At the interior point 'P' the x-coordinate is 3.3 and  $N_1=0.3$ . Determine  $N_2$ ,  $N_3$  and the y-coordinate at point P.

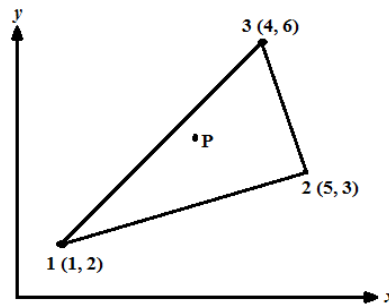

Figure 2

- b) Bring out the differences between a beam element and bar element. [5+5]

OR

- 7.a) For point p located inside the triangle as shown in figure 3. the shape functions  $N_1$  and  $N_2$  are 0.15 and 0.25 respectively. Determine the x-and y-coordiante of point P.

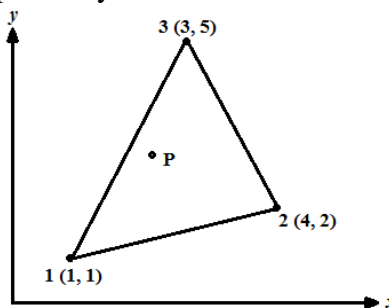

Figure 3

- b) Derive the elemental stiffness matrix for a two noded beam element. [5+5]

8. A composite slab consists of 3 materials of different conductivities i.e. 22 W/m K, 32 W/m K, 52 W/m K of thickness 0.31 m, 0.14 m and 0.14 m, respectively. The outer surface is 22<sup>0</sup> C and the inner surface is exposed to the convective heat transfer coefficient of 28 W/m<sup>2</sup> K at 800<sup>0</sup> C. Determine the temperature distribution within the wall. [10]

**OR**

- 9.a) Discuss in detail about 2D heat conduction in Composite slabs using FEA.  
b) Determine the temperature distribution along a circular fin of length 5 cm and radius 1 cm. The fin is attached to boiler whose wall temperature  $140^{\circ}\text{C}$  and the free end is open to the atmosphere. Assume  $T_{\infty} = 40^{\circ}\text{C}$ ,  $h = 10 \text{ W/cm}^2/^{\circ}\text{C}$ ,  $k = 70 \text{ W/cm}^{\circ}\text{C}$ . [5+5]
10. How to evaluate the Eigen values and Eigen vectors? Explain the properties of Eigen Values. [10]

**OR**

11. Explain the importance of element mass matrix in FEM with suitable example. [10]

---ooOoo---