

Subject Code: R10205/R10

Set No - 1

I B.Tech II Semester Supplementary Examinations July/Aug. - 2015

ENGINEERING DRAWING

(Common to All Branches)

Time: 3 hours

Max. Marks: 75

Answer any FIVE Questions

All Questions carry equal marks

*** * * * ***

- 1.(a) Construct an equilateral triangle ABC of 40 mm side. Construct a square, a regular pentagon and a regular hexagon on its sides AB, BC and CA respectively
- (b) Construct a Vernier scale of R.F = 1/80 to read inches and to measure upto 15 yards [8+7]
- 2.(a) A straight line AB of 50 mm long makes an angle of 30^0 to the H.P. The end A is 12 mm above the H.P, and 15 mm in front of the V.P. Draw the top view and front view of the line AB.
- (b) A point P is 50 mm above the H.P and 70 mm in front of the V.P. draw its projections [8+7]
- 3.(a) The front view of a line AB measures 65 mm and makes an angle of 45^0 with XY. A is in the HP and the VT of the line is 15 mm below the HP. The line is inclined at 30^0 to the VP. Draw the projections of AB and find its true length and inclination with the HP. Also locate its HT.
- (b) A line PQ 75 mm long has its end P in both H.P and V.P. It is inclined at an angle of 30^0 to H.P and 45^0 to V.P. Draw projections of the line. [8+7]
4. ABCD is a rhombus of diagonals AC = 110 mm and BD = 70 mm. Its corner A is in the H.P and the plane is inclined to the H.P. such that the plane appears to be a square. The plane of diagonal AC makes an angle of 20^0 to the V.P. Draw the projections of the plane and find its inclination with H.P. [15]
5. Draw the projections of a pentagonal prism, base 25 mm side and axis 50 mm long, resting on one of its rectangular faces on the HP, with the axis inclined at 45^0 to the VP. [15]
6. A right circular cone, base diameter 35 mm and axis 65 mm long, is resting on its circular rim in such a way that one of the generators normal to the H.P, and the plane of its axis makes an angle of 45^0 with the V.P. Draw its projections. [15]



Subject Code: R10205/R10

Set No - 2

I B.Tech II Semester Supplementary Examinations July/Aug. - 2015

ENGINEERING DRAWING

(Common to All Branches)

Time: 3 hours

Max. Marks: 75

Answer any FIVE Questions

All Questions carry equal marks

*** * * * ***

- 1.(a) Draw an ellipse whose major axis is 100 mm and minor axis is 60 mm. Draw a tangent to the curve at 30 mm from focus of the curve.
(b) Construct a diagonal scale of R.F = 1/6250 to read upto 1 kilometre and to read metres on it. Show a length of 653 metres on it. [8+7]
- 2.(a) A straight line AB, 60 mm long has its end A in both H.P and V.P. The straight line is inclined at 45° to H.P and 30° to V.P. Draw its projections.
(b) A point R is on the H.P and 60 mm behind the V.P. Draw its projections [8+7]
- 3.(a) A line AB 70 mm long is inclined at an angle of 40° to the H.P. and 30° to the V.P. The end A is in V.P and 30 mm above H.P. Draw the projections of the line and locate traces.
(b) Draw the projections of a line JK 70 mm long and touching both H.P and V.P. It is inclined at 40° to H.P and 35° to V.P. [8+7]
4. Draw the projections of a regular hexagon of 25 mm side, having one of its sides in the H.P and inclined at 60° to the V.P. and its surface making an angle of 45° with the H.P. [15]
5. A hexagonal prism, base edge 20 mm and height 50 mm, is resting on an edge of its base on H.P. in such a way that the base makes an angle of 45° with the H.P. Draw the projection of the prism. [15]
6. A right circular cone of 60 mm diameter of base and axis 75 mm long, is resting on one of its generators on horizontal plane in such a way that its axis makes an angle of 30° with the V.P, and apex towards V.P. Draw its projections [15]



Subject Code: R10205/R10

Set No - 3

I B.Tech II Semester Supplementary Examinations July/Aug. - 2015

ENGINEERING DRAWING

(Common to All Branches)

Time: 3 hours

Max. Marks: 75

**Answer any FIVE Questions
All Questions carry equal marks**

*** * * * ***

- 1.(a) Construct a regular octagon in a square of 75 mm side
(b) Draw a Vernier scale of R.F = 1/25 to read centimetres upto 4 metres and on it, show lengths representing 2.39 m and 0.91 m [8+7]
- 2.(a) Draw the projection of a straight line AB, 80 mm long which is inclined at 30° to the H.P and 45° to the V.P. The end point A is 20 mm from the H.P and 10 mm from the V.P
(b) A point R is 80 mm below the H.P and 50 mm behind the V.P. Draw its projections [8+7]
- 3.(a) The distance between the end projectors of a straight line AB is 60 mm. Point A is 5 mm above HP and 30 mm in front of VP. Point B is 40 mm above HP and 50 mm behind VP. Draw the projections and find the inclination of straight line AB with HP and VP and true length of the line. Find also the traces.
(b) A line measuring 80 mm long has one of its ends 60 mm above HP and 20 mm in front of VP. The other end is 15 mm above HP and its front of VP. The front view of the line is 60 mm long. Draw the top view. [8+7]
4. The top view of a circle of 50 mm diameter is an ellipse with major axis 50 mm and minor axis 30 mm, with the major axis inclined at 60° to VP. Draw the projections of the plane and find its inclination with HP. [15]
5. Draw the projections of a cylinder 40 mm diameter and axis 55 mm long is resting on a point of base circle on HP, with its axis inclined at 45° to HP and parallel to VP. [15]
6. A pentagonal pyramid, side of base 25 mm and height 60 mm has one of its slant faces on the horizontal plane and the edge of the base contained by that slant face makes an angle of 30° to the V.P. Draw its projections. [15]



Subject Code: R10205/R10

Set No - 4

I B.Tech II Semester Supplementary Examinations July/Aug. - 2015

ENGINEERING DRAWING

(Common to All Branches)

Time: 3 hours

Max. Marks: 75

Answer any FIVE Questions

All Questions carry equal marks

*** * * * ***

- 1.(a) The major and minor axes of an ellipse are 120 mm and 80 mm. Draw an ellipse by using Oblong method
(b) Draw a diagonal scale of R.F = 1 : 20,000 to show kilometers and decimals of a kilometer. Mark 1.86 Km and 2.34 Km on the scale. [8+7]
- 2.(a) A straight line AB, 55 mm long makes an angle of 30° to the HP and 45° to the VP. The end A is 12 mm in front of VP and 15 mm above HP. Draw the projections of the line AB
(b) A point Q is 70 mm above the HP and on the VP. Draw its projections. [8+7]
- 3.(a) The top view and the front view, of the line CD, measure 65 mm and 53 mm respectively. The line is inclined to HP and VP by 30° and 45° respectively. The end C is on the HP and 12 mm in front of VP. Other end D is in the 1st quadrant. Draw the projections of the line CD and find its true length and draw traces.
(b) A line AB 60 mm long makes an angle 45° to the VP. The end A is 15 mm from the HP and 12 mm from the VP. Draw the top view and front view of the line AB. [8+7]
4. A pentagonal plane of 30 mm side has one of its sides in the VP and inclined at 60° to the HP while the surface of the plane makes an angle of 40° to VP. Draw its projections. [15]
5. A hexagonal prism, base 40 mm side and height 40 mm has a hole of 40 mm diameter drilled centrally through its ends. Draw its projections when it is resting on one of its corners on the HP with its axis inclines at 60° to the HP and two of its faces parallel to the VP. [15]
6. A hexagonal pyramid, side of base 25 mm and 50 mm long, is resting on an edge of its base on the horizontal plane in such a way that it makes an angle of 45° to VP. The slant face containing the same edge makes an angle of 60° to the HP. [15]



7. Draw (i) Front view (ii) Side view from the right (iii) Top view

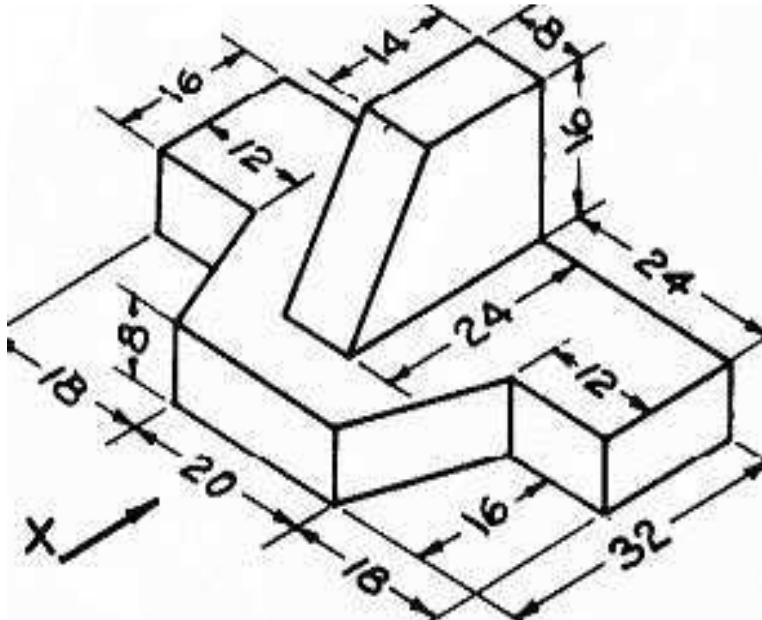

Note: All dimensions are in mm

8. Draw the isometric view

[15]

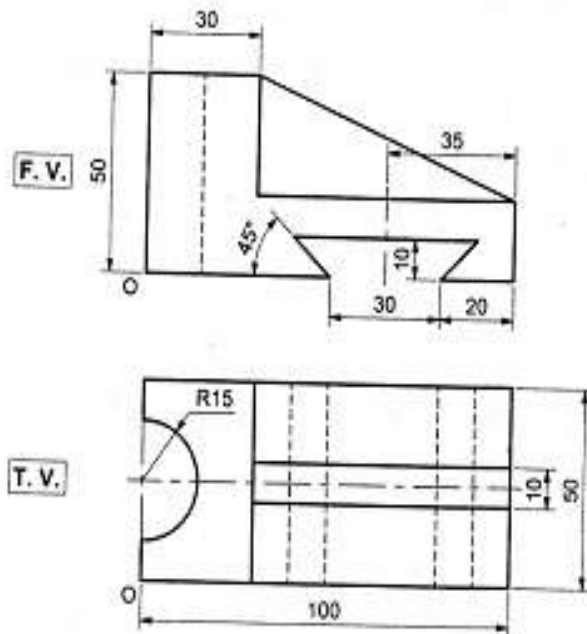

Note: All dimensions are in mm

[15]

