

I B. Tech II Semester Regular Examinations August - 2014

NETWORK ANALYSIS

(Common to ECE, EIE, E Com.E Branches)

Time: 3 hours

Max. Marks: 70

Question Paper Consists of **Part-A** and **Part-B**
 Answering the question in **Part-A** is Compulsory,
 Three Questions should be answered from **Part-B**

PART-A

- 1.(i) Define electric potential, electric current and electric energy.
- (ii) A certain inductive coil takes 15 A when the supply voltage is 230 V, 50 Hz. If the frequency is changed to 40 Hz, the current increases to 17.2 A. Calculate resistance and inductance of the coil.
- (iii) Write the differences between series and parallel resonance.
- (iv) State compensation theorem.
- (v) Write the Z-parameters of the following network (Figure:1):

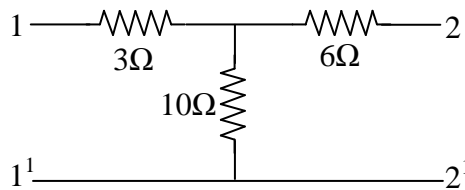

Figure:1

- (vi) What is time constant? What are the time constant of series R-L and R-C circuit?
- (vii) A series R-L circuit has R=20 ohms and L=8 H. The circuit is connected across a DC voltage source of 120 V at t=0. Calculate the time at which the voltage drops across R and L are the same.

[2+4+3+2+4+3+4]

PART-B

- 2.(a) State and explain Kirchoff's voltage and current law with an example.
- (b) Find the voltage V(t) in the network shown in figure:2 using nodal technique. All impedances are in ohms.

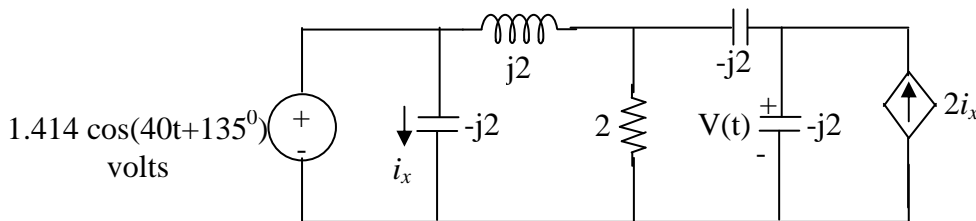

Figure:2

[6+10]



- 3.(a) A sinusoidal 50 Hz voltage of 200 V supplies three parallel circuits as shown in figure:3. Find the current in each circuit and the total current. Draw the vector diagram. Assume supply voltage $V=200V$, 50 Hz.

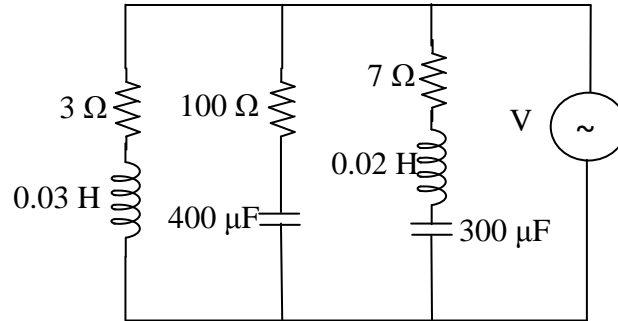

Figure:3

- (b) The impedances of a parallel circuit are $Z_1=(6 + j8)$ ohms and $Z_2 = (8 - j6)$ ohms. If the applied voltage is 120V, find (i) current and power factor of each branch (ii) overall current and power factor of the combination (iii) power consumed by each impedance. Draw a phasor diagram. [8+8]
- 4.(a) Obtain an expression for coefficient of coupling.
 (b) Two similar coils connected in series gave a total inductance of 600 mH and when one of the coil is reversed, the total inductance is 300 mH. Determine the mutual inductance between the coils and coefficient of coupling.
 (c) State and explain Maximum power transfer theorem. [5+5+6]
- 5.(a) For a series resonant circuit with constant voltage and variable frequency, obtain the frequency at which voltage across the inductor is maximum. Calculate this maximum voltage when $R=50$ ohms, $L=0.05H$, $C=20$ micro farad and $V=100$ volts.
 (b) Determine the current through $R_L=10 \Omega$ resistor as shown in figure:4 using Thevenin's theorem. Verify the same with Norton's theorem.

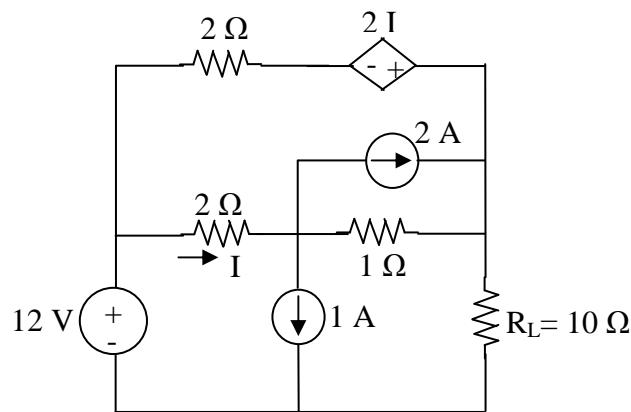
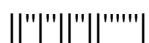

Figure:4

[6+10]



- 6.(a) Derive the symmetry and reciprocity conditions for ABCD parameters and h-parameters.
 (b) Determine the Y- parameters of the network shown in figure:5.

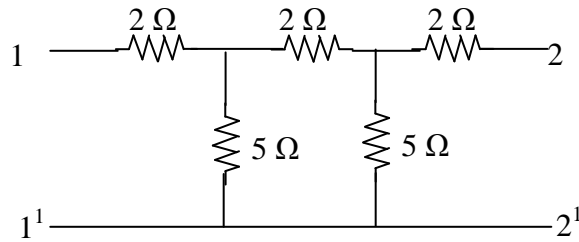

Figure:5

7. A series R-C circuit with $R=10$ ohms and $C= 2F$ has a sinusoidal voltage source $200 \sin(500t + \phi)$ applied at time when $\phi = 0$. (i) Find the expression for current (ii) At what value of ϕ must the switch be closed so that the current directly enter steady state.

[8+8]

[16]

I B. Tech II Semester Regular Examinations August - 2014

NETWORK ANALYSIS

(Common to ECE, EIE, E Com.E Branches)

Time: 3 hours

Max. Marks: 70

Question Paper Consists of **Part-A** and **Part-B**
 Answering the question in **Part-A** is Compulsory,
 Three Questions should be answered from **Part-B**

PART-A

- 1.(i) Define average value, RMS value and form factor for an alternating quantity.
- (ii) Determine the source voltage and phase angle, if the voltage across the resistance is 70 V and across an inductive reactance is 20 V, in an R-L series circuit.
- (iii) For the circuit shown in figure:1, determine the value of capacitive reactance, impedance and current at resonance.

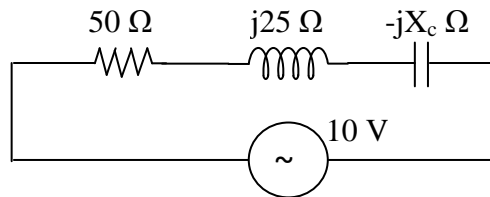

Figure:1

- (iv) State maximum power transfer theorem.
- (v) Write condition of symmetry and reciprocity for transmission, inverse transmission and inverse h-parameters.
- (vi) What is meant by natural and forced response?
- (vii) In a series R-L circuit, the application of DC voltage results in a current of 0.741 times the final steady state value of current after one second. However, after the current has reached its final value, the source is short-circuited. What would be the value of the current after one second?

[3+3+3+2+4+3+4]

PART-B

- 2.(a) For the circuit shown in figure:2, find all the branch currents using nodal analysis. Also show that total power delivered is equal to total power dissipated.

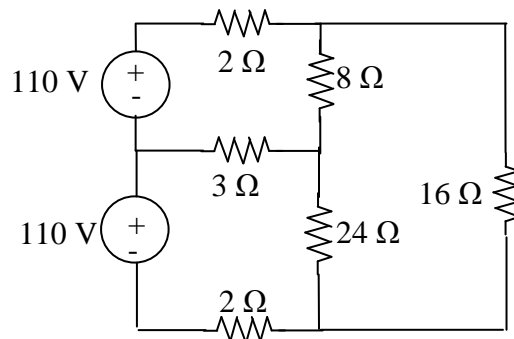

Figure 2



2.(b) A current of 5 A flows through a non inductive resistance in series with a choking coil when supplied at 250 V, 50 Hz. If the voltage across the non inductive resistance is 125V and that across the coil 200V, calculate Impedance, Reactance and Resistance of the coil, and power absorbed by the coil. Also draw the phasor diagram. [8+8]

3.(a) Define incidence matrix. For the graph shown in figure:3, find the complete incidence matrix.

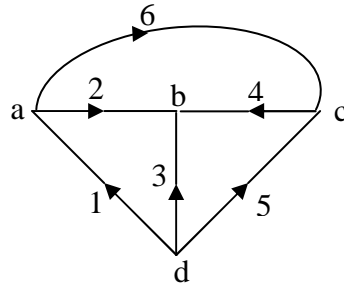

Figure:3

(b) Two impedances $Z_1=10+j31.4$ ohms and $Z_2=(10+R)+j(31.4-X_c)$ ohms are connected in parallel across a single phase AC supply. The current taken by the two impedance branches are equal in magnitude and the phase angle between them is 90° . Calculate the value of R and X_c and phase difference of the branch currents with respect to the applied voltage. [8+8]

4.(a) State and explain the Tellegen’s theorem.

(b) For the network shown in the figure:4, determine (i) Resonance frequency (ii) input admittance at resonance (iii) quality factor (iv) band width.

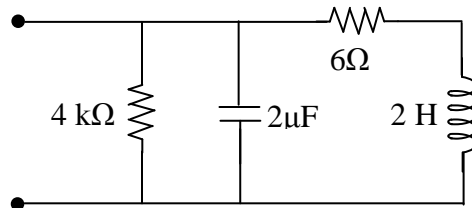

Figure:4

5.(a) Two coils A and B having turns 100 and 1000 respectively are wound side by side on closed circuit coil of X-section 8 cm^2 and mean length 80 cm. The relative permeability of iron is 900. Calculate the mutual inductance between the coils. [7+9]



- 5.(b) Determine the current through load resistance $R_L=5 \Omega$ for the circuit shown in figure:5 using Thevenin's theorem. Also find the maximum power transfer to the resistance R_L .

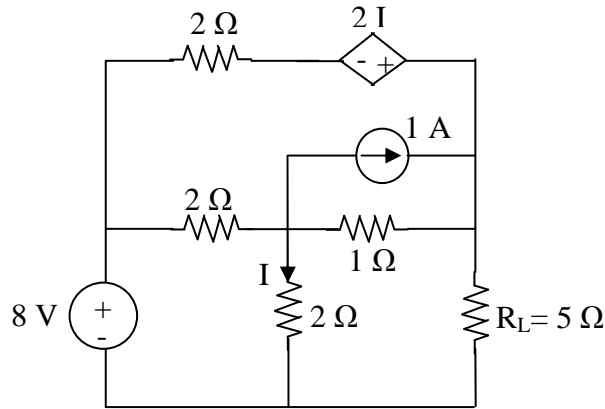

Figure:5

[7+9]

- 6.(a) Express Y-parameters in terms of ABCD and Z-parameters.
 (b) Determine the h-parameters of the following network as shown in figure:6.

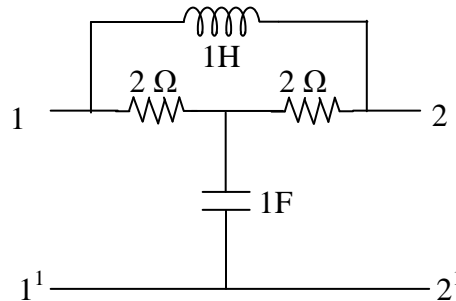

Figure:6

[7+9]

7. In a series RLC circuit, $R=6$ ohms, $L=1$ H, $C=1$ F. A DC voltage of 40 V is applied at $t=0$. Obtain the expression for $i(t)$ using differential equation approach. Explain the procedure to evaluate conditions.

[16]



I B. Tech II Semester Regular Examinations August - 2014

NETWORK ANALYSIS

(Common to ECE, EIE, E Com.E Branches)

Time: 3 hours

Max. Marks: 70

Question Paper Consists of **Part-A** and **Part-B**
 Answering the question in **Part-A** is Compulsory,
 Three Questions should be answered from **Part-B**

PART-A

- 1.(i) Give the statements of Kirchhoff's voltage and current law. Write applications also.
- (ii) Write the expression for total impedance of the circuit having (i) only resistance (ii) pure inductor (iii) Pure capacitor (iv) R-L parameters (v) R-C parameters (vi) R-L-C parameters. Write the expression for phase difference in all the above cases.
- (iii) Define self, mutual inductance and coefficient of coupling.
- (iv) State superposition theorem.
- (v) Write the condition of symmetry and reciprocity for Z, Y and h-parameters.
- (vi) A resistance R and a 3 μF capacitor are connected in series across a 240 V DC supply. A voltmeter is connected across the capacitor. Calculate R so that the voltmeter reads 160 Vat 5.5 seconds after closing the switch.
- (vii) Write the expression for total inductance of the three series connected coupled coils connected between A and B as shown in figure:1.

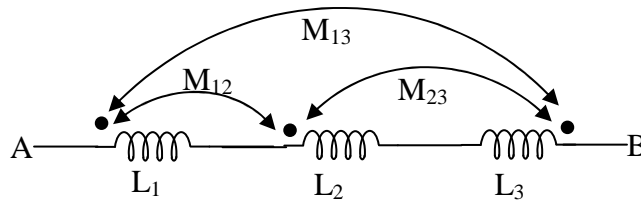

Figure:1

[3+4+3+2+3+3+4]

PART-B

- 2.(a) Determine the voltage V in the circuit shown in figure:2.

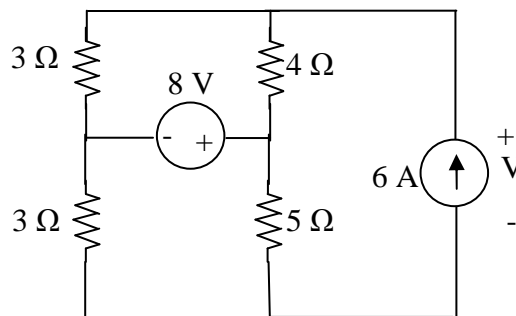

Figure:2



2.(b) An inductive load connected to a 230 V, 50 Hz source takes a current of 15 A and dissipates 2000 W. Determine the power factor of the load. Also determine the parallel capacitance required to improve power factor to 0.9 lagging. What would be the total current taken from the supply.

[8+8]

3.(a) Find i_l in circuit shown in figure:3, using nodal analysis. Assume the supply voltage $V(t)=20 \cos(4t)$ volts.

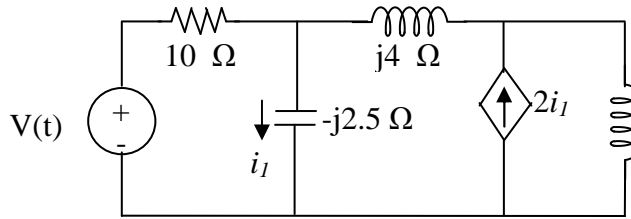

Figure:3

(b) A coil having a resistance of 50 ohms and an inductance of 0.02 H is connected in parallel with a capacitor of 25 μ F, across a 200 V, 50 Hz supply. Find the current in the coil and the capacitor. Also find the total current taken from the supply, the overall power factor and total power consumed. Draw the phasor diagram.

[8+8]

4.(a) In a series RLC circuit with variable capacitance, the current is at maximum value with capacitance of 20 μ F and the current reduces to 0.707 times the maximum value with a capacitance of 30 μ F. Find the values of R and L. What is the bandwidth of the circuit if supply voltage is $V(t)=20 \sin(6280t)$ volts?

(b) State and explain Reciprocity and Compensation theorems.

[8+8]

5.(a) Show that the resonant frequency ω_0 of an RLC series circuit is the geometric mean of ω_1 and ω_2 , the lower and upper half-power frequencies respectively.

(b) Verify the Tellegen's theorem for the circuit shown in Figures:4.

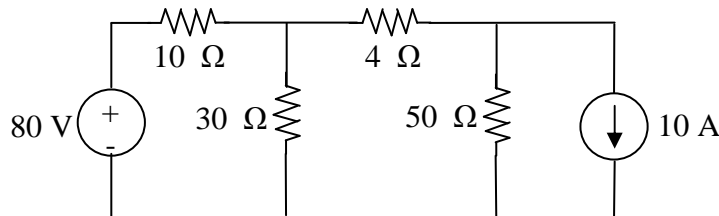

Figure:4

[8+8]



- 6.(a) Express z -parameters in terms of h -parameters and $ABCD$ -parameters.
 (b) Determine the Z -parameters for the network shown in fig:5.

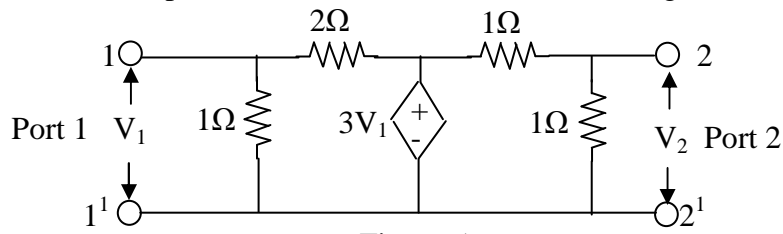
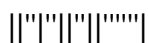

Figure:5

7. For an R-L series circuit, a sinusoidal voltage $v(t) = V_m \sin(\omega t + \phi)$ is applied at $t=0$. Find the expression for transient current.

[8+8]

[16]



I B. Tech II Semester Regular Examinations August - 2014

NETWORK ANALYSIS

(Common to ECE, EIE, E Com.E Branches)

Time: 3 hours

Max. Marks: 70

Question Paper Consists of Part-A and Part-B
Answering the question in Part-A is Compulsory,
Three Questions should be answered from Part-B

PART-A

- 1.(i) Define Tie-set, Cut-set and incidence matrix
(ii) Explain why current leads the voltage by 90 degrees in case of ideal capacitor and current lags the voltage by 90 degrees in case of ideal inductor.
(iii) Two coupled coils with L1=0.01 H and L2=0.04 H and K=0.6 are connected in four different ways. Find the equivalent inductance if coils are connected in (a) series aiding (b) series opposing (c) parallel aiding (iv) parallel opposing.
(iv) State substitution theorem.
(v) Construct circuits that realize the following Z-parameters: Z = [12 4; 4 8]
(vi) Why current in the inductor and voltage across the capacitor does not change instantaneously.
(vii) How the R-L-C circuit behaves for the frequencies above and below the resonant frequencies.

[3+4+4+2+3+3+3]

PART-B

- 2.(a) Define average value, RMS value, form factor and peak factor and calculate the same for the following periodic waveform shown in figure:1.

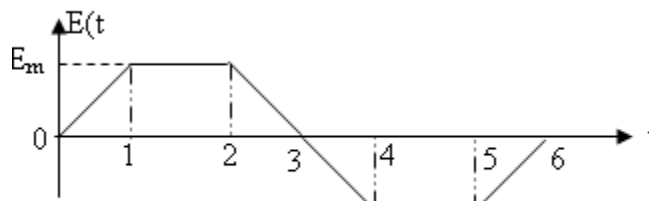
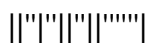

Figure:1

- (b) A series circuit consisting of non-inductive resistance and a choking coil are connected across a 250 V, 50 Hz supply. If the voltage across the resistance is 120 V and across the coil is 190 V, draw the phasor diagram and calculate (i) impedance, reactance and resistance of the coil (ii) the power absorbed by the coil (iii) the total power.

[8+8]



- 3.(a) Find the total power delivered in the circuit using mesh analysis for the circuit shown in figure:2.

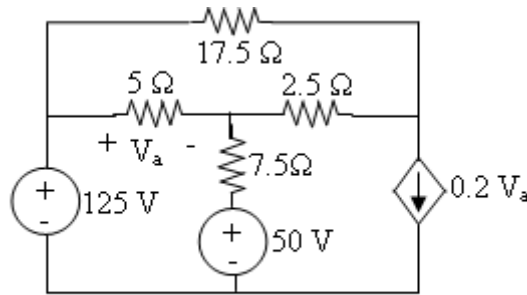

Figure:2

- (b) A series RLC circuit with $R = 10$ ohms, $L = 0.4$ H and $C = 50 \mu\text{F}$ has applied voltage of 200V with variable frequency. Calculate the resonant frequency, current at resonance, voltage across R, L and C. Also calculate the Q-factor, upper and lower half power frequencies and bandwidth. [8+8]
- 4.(a) A series combination of R and C is in parallel with a 25 ohms resistor. A 50 Hz source results in a total current of 6.5 A, a current of 5 A through 25 ohms resistance and a current of 2.3 A in the R-C branch. (i) Draw the phasor diagram of the circuit and find values of R and C (ii) Find apparent, active, reactive power and power factor of the circuit.
- (b) Determine voltage V across a 15 ohms resistor in the magnetically coupled circuit shown in Figure:3. Take $V_s = 30\angle 40^\circ$.

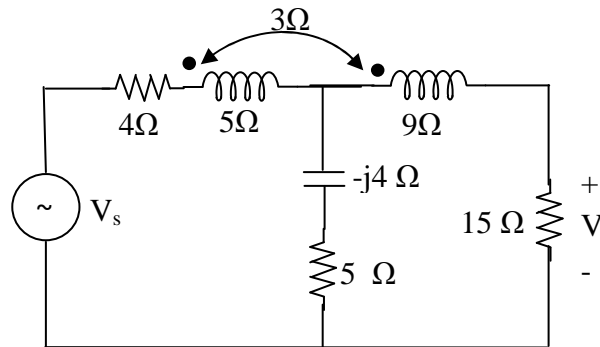
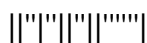

Figure:3

- 5.(a) The Z-parameters of a two port network are $Z_{11}=15 \Omega$, $Z_{22}=24 \Omega$, $Z_{12}=Z_{21}=6 \Omega$. Determine ABCD and h-parameters. [8+8]



- 5.(b) Find the voltage across $-j20 \Omega$ capacitor using superposition theorem in below Figure:4. All impedance values are in ohms.

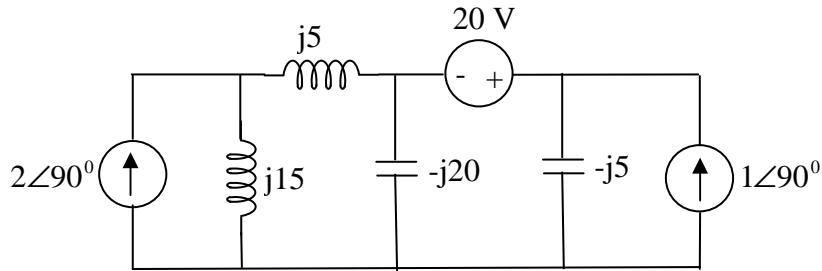

Figure:4

[7+9]

- 6.(a) Prove that the power transfer to the load becomes maximum when the load impedance is equal to the complex conjugate of the Thevenin's impedance.
 (b) Determine the ABCD parameters of the network shown in figure:5.

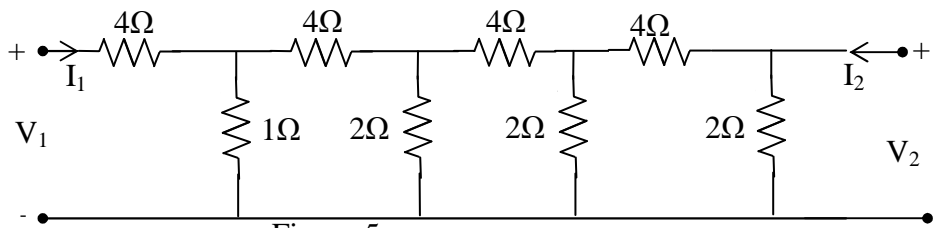

Figure:5

[7+9]

7. For an RC series circuit, a sinusoidal voltage $v(t) = V_m \sin \omega t$ is applied at $t=0$. Find the expression for transient current using both differential equation approach and Laplace transform approach.

[16]

